

Transmission

Cost Allocation and Rates

2011/2012 Transmission Rate Application Stakeholder Consultation

March 2, 2010

Michael Roger

Manager - Pricing



PRELIMINARY

Presentation Overview

- Major Contributing Factors to Increase
- Primary Rate Pools
- Allocation of Assets and Costs
- Preliminary Revenue Requirement
- Preliminary Charge Determinants
- Projected Rates
- Projected Impacts

Major Contributing Factors to Increase (%)

	<u>2011</u>	<u>2012</u>
Growth in Asset	8.3	7.1
Increase in OM&A	1.4	1.4
Increase in Cost of Capital	1.2	0.8
Reduction in Load	1.4	0.2
Bruce to Milton CWIP	3.5	0.8
Taxes	(0.5)	(1.4)
Riders	0.8	0.8
Other	<u>0.1</u>	<u>0.1</u>
Total Impacts	16.2	9.8

Primary Rate Pools -- no change

Network Pool

- Paid by all transmission customers. Includes integrated Transmission system assets serving all customers
- **Includes network portion of Dual Function Lines and Generator portion of line and transformation**

Line Connection Pool

- Paid by customers using Transmission Lines and related functions dedicated to one or few customers
- **Includes connection portion of Dual Function Lines**

Transformation Connection Pool

- Paid by customers using Transmission station assets that step-down voltage from above 50kV to below 50kV

Transmission Meter Pool

- Paid by customers for whom Hydro One provides regulated Meter service

Allocation of Assets to Primary Pools

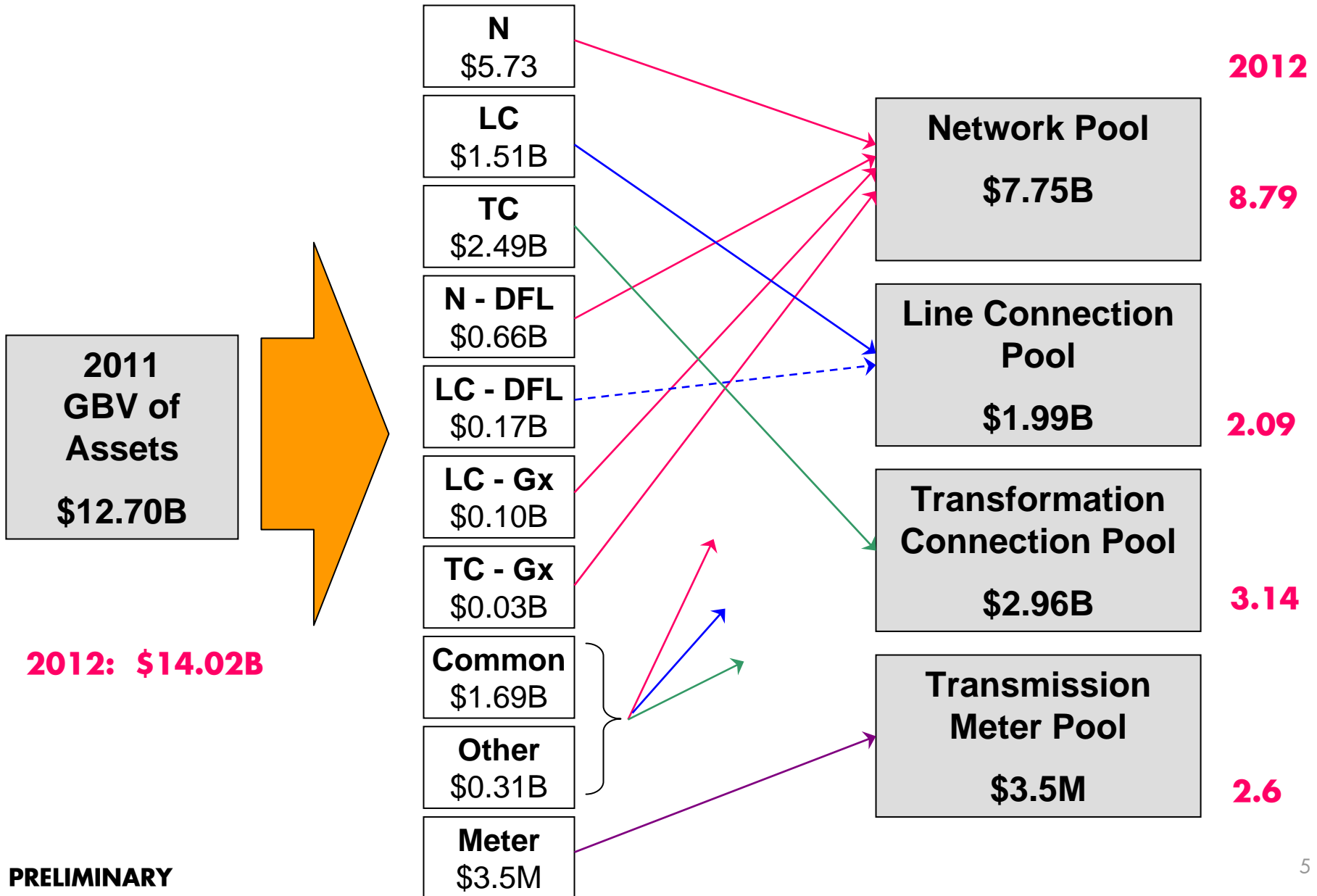

Rate Pool Terminology

- N = Network
- LC = Line Connection
- TC = Transformation Connection
- N-DFL = Network Dual Function Lines
- LC-DFL = Line Connection Dual Function Lines
- LC-Gx = Line Connection Generation
- TC-Gx = Transformation Connection Generation
- Meter = Transitional Wholesale Meter

Allocation Of OMA Costs excl Taxes

Preliminary

	Network	Line	Transf	Meter	Total
2011 [\$M]	226	44	114	1	385
	59%	11%	30%	0%	100%
2012 [\$M]	237	44	117	0.4	398
	60%	11%	29%	0%	100%

Allocation Of Depreciation Costs Preliminary

	Network	Line	Transf	Meter	Total
2011 [\$M]	178	41	79	0.1	298
	60%	14%	26%	0%	100%
2012 [\$M]	202	43	83	0.1	329
	62%	13%	25%	0%	100%

Allocation of Other Costs

Other Revenue Requirement

	2011 (\$M)	2012 (\$M)
Asset Removal Costs (- capitalized dep'n)	9	9
Amortization	7	8
Return on Debt	300	335
Return on Equity	361	411
Taxes	152	145
Non-Rate Revenues	(52)	(33)
Total	777	875

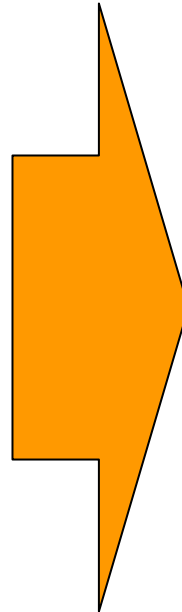

RATE BASE SHARE

	2011	2012
Network	\$475M 61%	\$548M 63%
LC	\$123M 16%	\$129M 15%
TC	\$179M 23%	\$198M 23%
Mtr	\$0.2M .02%	\$0.2M .02%

PRELIMINARY

Summary of Preliminary Rates Revenue Requirement

Rate Pool	2011 (\$M)	2012 (\$M)
Network	878.6	986.6
Line Connection	207.7	215.3
Transformation Connection	384.9	411.5
Meter	0.9	0.7
Total	1,472.1	1,614.2

Primary Pool Charge Determinants

Rate Pool	Determinant Basis	2011 (Avg MW/mo)	2012 (Avg MW/mo)
Network	Higher of CP or 85% NCP (7am-7pm)	19,922	19,845
Line Connection	NCP	19,284	19,286
Transformation Connection	NCP	16,664	16,667
Transmission Meter	# of meter points mid year	100	75

Projected Provincial Rates

- Uniform Transmission Rates = UTR
- Used the existing model with updates
- New H1N-Tx Rates Revenue Requirement and Charge Determinants by Rate Pool
- Assumed constant levels for other transmitters
 - Jan 1, 2010 Uniform Transmission Rate per motion

DRAFT

Summary Uniform Transmission Rates and Revenue Disbursement Factors
for Rates Effective January 1, 2011

Transmitter	Revenue Requirement (\$)			
	Network	Line Connection	Transformation Connection	Total
FNEI	\$3,092,193	\$731,055	\$1,354,753	\$5,178,000
CNPI	\$2,754,454	\$651,207	\$1,206,782	\$4,612,443
GLPL	\$20,773,123	\$4,911,171	\$9,101,128	\$34,785,422
H1N (Note 1)	\$878,585,412	\$207,714,704	\$384,926,135	\$1,471,226,251
All Transmitters	\$905,205,182	\$214,008,136	\$396,588,797	\$1,515,802,116

Transmitter	Total Annual Charge Determinants (MW)			
	Network	Line Connection	Transformation Connection	
FNEI	44.9	44.9	44.9	
CNPI	583.4	668.6	668.6	
GLPL	4,150.5	2,847.0	2,777.9	
H1N (Note 2)	239,065.9	231,405.8	199,971.3	
All Transmitters	243,844.7	234,966.3	203,462.8	

Transmitter	Uniform Rates and Revenue Allocators			
	Network	Line Connection	Transformation Connection	
Uniform Transmission Rates (\$/kW -Month)	3.71	0.91	1.95	
FNEI Allocation Factor	0.00342	0.00342	0.00342	
CNPI Allocation Factor	0.00304	0.00304	0.00304	
GLPL Allocation Factor	0.02295	0.02295	0.02295	
H1N Allocation Factor	0.97059	0.97059	0.97059	
Total of Allocation Factors	1.00000	1.00000	1.00000	

Note 1: Hydro One Networks (H1N) Revenue Requirement per Exhibit 6.2 in Hydro One Networks'

Note 2: Hydro One Networks (H1N) Charge Determinant per Exhibit 6.3 in Hydro One Networks'

Note 3: Data for Other Transmitters per Exhibit 4.1 in Hydro One Networks' submission to the

Note 4: Calculated data in shaded cells.

Uniform Transmission Rates Revenue Requirement

DRAFT

Summary Uniform Transmission Rates and Revenue Disbursement Factors
for Rates Effective January 1, 2011

Transmitter	Revenue Requirement (\$)			
	Network	Line Connection	Transformation Connection	Total
FNEI	\$3,092,193	\$731,055	\$1,354,753	\$5,178,000
CNPI	\$2,754,454	\$651,207	\$1,206,782	\$4,612,443
GLPL	\$20,773,123	\$4,911,171	\$9,101,128	\$34,785,422
HIN(Note 1)	\$878,585,412	\$207,714,704	\$384,926,135	\$1,471,226,251
All Transmitters	\$905,205,182	\$214,008,136	\$396,588,797	\$1,515,802,116

Uniform Transmission Rates Charge Determinants

DRAFT

Summary Uniform Transmission Rates and Revenue Disbursement Factors
for Rates Effective January 1, 2011

Transmitter	Total Annual Charge Determinants (MW)			
	Network	Line Connection	Transformation Connection	
FNEI	44.9	44.9	44.9	
CNPI	583.4	668.6	668.6	
GLPL	4,150.5	2,847.0	2,777.9	
HIN (Note 2)	239,065.9	231,405.8	199,971.3	
All Transmitters	243,844.7	234,966.3	203,462.8	

Uniform Transmission Rates and Revenue Allocators

DRAFT

Summary Uniform Transmission Rates and Revenue Disbursement Factors
for Rates Effective January 1, 2011

Transmitter	Uniform Rates and Revenue Allocators			
	Network	Line Connection	Transformation Connection	
Uniform Transmission Rates (\$/kW-Month)	3.71	0.91	1.95	
FNEI Allocation Factor	0.00342	0.00342	0.00342	
CNPI Allocation Factor	0.00304	0.00304	0.00304	
GLPL Allocation Factor	0.02295	0.02295	0.02295	
H1N Allocation Factor	0.97059	0.97059	0.97059	
Total of Allocation Factors	1.00000	1.00000	1.00000	

Note 1: Hydro One Networks (H1N) Revenue Requirement per Exhibit 6.2 in Hydro One Networks'

Note 2: Hydro One Networks (H1N) Charge Determinant per Exhibit 6.3 in Hydro One Networks'

Note 3: Data for Other Transmitters per Exhibit 4.1 in Hydro One Networks' submission to the

Note 4: Calculated data in shaded cells.

Projected Uniform Transmission Rates

Rate Pool	Jan1, 2010*	2011	2012
Network	3.13	3.71	4.17
Line Connection	0.77	0.91	0.94
Transformation Connection	1.79	1.95	2.08
Meter	\$7,000	\$8,700	\$8,700

*2010 UTR per Motion

Note: N, LC and TC Rates are \$ / kW – month
Meter Rate is per meter point per year

PRELIMINARY

Projected UTR Tx Impacts – 2011

	Jan 1, 2010 [\$M]	Proposed 2011 [\$M]	\$Incr [\$M]	% Incr	Range	Total Bill %
Directs	74.9	88.6	13.7	18.3	15.2 to 18.5	1.5
LDCs	1,202.9	1,391.0	188.2	15.6	12.9 to 18.5	2.0
Generators	6.6	7.8	1.2	18.2	14.7 to 18.5	2.0
Total	1,284.4	1,487.5	203.1	15.8	12.9 to 18.5	1.9

Projected UTR Tx Impacts 2012 vs 2011

	Proposed 2011 [\$M]	Proposed 2012 [\$M]	\$Incr [\$M]	% Incr	Range %	Total Bill %
Directs	88.6	97.8	9.1	10.3	3.5 to 12.4	1.0
LDCs	1,391.0	1,523.9	132.9	9.6	7.9 to 12.4	1.4
Generators	7.8	8.7	0.9	11.8	3.3 to 12.4	1.5
Total	1,487.5	1,630.4	142.9	9.6	3.3 to 12.4	1.3