



Southern Huron-Perth Sub-Region Integrated Regional Resource Plan

Part of the Greater Bruce/Huron Planning Region

September 2021

Table of Contents

1	Introduction	7
2	The Integrated Regional Resource Plan	11
2.1	Reference Scenario Needs	11
2.2	High Growth Scenario Needs	11
2.3	Conservation and Demand Management	12
3	Development of the Plan	14
3.1	The Regional Planning Process	14
3.2	Southern Huron-Perth and IRRP Development	14
4	Background and Study Scope	15
4.1	Study Scope	15
5	Electricity Demand Forecast	17
5.1	Demand Forecast Methodology	17
5.2	Historical Electricity Demand	18
5.3	Gross and Net Demand Forecast	19
5.4	Contribution of Conservation to the Forecast	20
5.5	Contribution of Distributed Generation to the Forecast	22
5.6	Demand Forecast Scenarios	22
5.7	Project to Consider for Next Cycle	23
6	Needs	24
6.1	Needs Assessment Methodology	24
6.2	Needs Identified	25
7	Plan Options and Recommendations	26
7.1	Long-term Needs	26
8	Engagement	30
8.1	Engagement Principles	30

8.2	Creating an Engagement Approach for Southern Huron-Perth	30
8.3	Engage Early and Often	31
8.4	Bringing Communities to the Table	32
8.5	Engaging with Indigenous Communities	32
9	Conclusion	33
Appendix A.	Methodology and Assumptions for Demand Forecast	34
A.1	Method for Accounting for Weather Impact on Demand	34
A.2	Hydro One Forecast Methodology	35
A.3	Festival Hydro Forecast Methodology	36
A.4	Entegrus Powerlines Inc. Forecast Methodology	37
A.5	Conservation Assumptions in Demand Forecast	38
Appendix B.	Solution Options to Supply Capacity Need in the High Growth Scenario	43
Appendix C.	Development of the Plan	44
C.1	The Regional Planning Process	44
C.2	IESO’s Approach to Regional Planning	46

List of Tables and Figures

List of Tables

Table A.1 Growth Rates for Ontario’s GDP (%).....	36
Table A.2 Ontario’s Housing Starts (in thousands)	36
Table A.3 Reference Summer Non-Coincident Extreme Peak Demand Forecast (MW) per Station in Southern Huron-Perth Sub-Region.....	40
Table A.4 Reference Summer Coincident Extreme Peak Demand Forecast (MW) per Station in Southern Huron-Perth Sub-Region.....	40
Table A.5 High Growth Summer Coincident Extreme Peak Demand Forecast (MW) per Station in Southern Huron-Perth Sub-Region.....	41
Table A.6 CDM and DG Contribution (MW) Considered in Reference Coincident Extreme Peak Demand Forecast.....	41
Table A.7 Reference Summer LDC Coincident Gross Peak Demand Forecast (MW) per Station in Southern Huron-Perth Sub-Region.....	42

List of Figures

Figure 1.1 Map of the Southern Huron-Perth Sub-Region	8
Figure 1.2 Electricity Infrastructure in the Southern Huron-Perth Sub-Region.....	9
Figure 1.3 Single Line Diagram of the Southern Huron-Perth Sub-Region, exclusive of the 230 kV system.....	9
Figure 5.1 Development of Demand Forecast	17
Figure 5.2 Measured & Weather Corrected Coincident Net and Gross Historical Peak Demand in the Southern Huron-Perth sub-region.....	18
Figure 5.3 Normal/Extreme Weather Corrected Coincident Net and Gross Peak Demand in the Southern Huron-Perth sub-region.....	19
Figure 5.4 Reduction to Demand Forecast due to Conservation by Sector (2019-2020 CDM Framework, 2015-2020 Conservation First Framework and Codes and Standards)	21
Figure 5.5 Reduction to Demand Forecast due to Conservation by Program.....	21
Figure 5.6 Reduction to Demand Forecast due to DG and Conservation.....	22
Figure 5.7 Demand Forecast Scenarios	23
Figure 6.1 Needs Identified for the Southern Huron-Perth sub-region.....	25
Figure 7.1 CDM Savings Potential under the High Growth Scenario	28
Figure 8.1 The IESO’s Engagement Principles.....	30

Figure A.1 | Method for Determining the Weather-Normalized Peak 35
Figure A.2 | Entegrus' Licensed Utility Service Area within Southern Huron-Perth – Parkhill 37

List of Abbreviations

CDM	Conservation Demand Management
CTS	Customer Transformer Station
DER	Distributed Energy Resources
DG	Distributed Generation
FIT	Feed-in Tariff
GDP	Gross Domestic Product
Hydro One	Hydro One Networks Inc.
IESO	Independent Electricity System Operator
IRRP	Integrated Regional Resource Plan
JCT	Junction
kV	Kilovolt
LDC	Local Distribution Company
LMC	Load Meeting Capability
LTR	Limited Time Rating
LV	Low-voltage
MW	Megawatt
NERC	North American Electric Reliability Corporation
OEB	Ontario Energy Board
OPA	Ontario Power Authority
ORTAC	Ontario Resource and Transmission Assessment Criteria
PPWG	Planning Process Working Group
RIP	Regional Infrastructure Plan
TS	Transformer Station
Working Group	Technical Working Group of the Southern Huron-Perth sub-region

This Integrated Regional Resource Plan (IRRP) was prepared by the Independent Electricity System Operator (IESO) pursuant to the terms of its Ontario Energy Board licence, EI-2013-0066.

This IRRP was prepared on behalf of the Technical Working Group (Working Group) of the Southern Huron-Perth sub-region which included the following members:

- Entegrus Powerlines Inc.
- Festival Hydro
- Hydro One Networks Inc. (Distribution)
- Hydro One Networks Inc. (Transmission)
- Independent Electricity System Operator

The Working Group assessed the adequacy of electricity supply to customers in the Southern Huron-Perth sub-region over a 20-year period beginning in 2019; developed a plan that considers opportunities for coordination in anticipation of potential demand growth and varying supply conditions in the region; and developed an implementation plan for the recommended options, while maintaining flexibility in order to accommodate changes in key conditions over time.

The Southern Huron-Perth Working Group members agree with the IRRP's recommendations and support implementation of the plan, subject to obtaining necessary regulatory approvals and appropriate community consultations.

The Southern Huron-Perth Working Group members do not commit to any capital expenditures and must still obtain all necessary regulatory and other approvals to implement recommended actions.

1 Introduction

This Integrated Regional Resource Plan (IRRP) addresses the regional electricity needs for the Southern Huron-Perth sub-region for the next 20 years (the “study period”).

Southern Huron-Perth is a sub-region of the Greater Bruce/Huron region. The Greater Bruce/Huron region is located in southwestern Ontario and comprises the counties of Bruce, Huron and Perth, as well as portions of Grey, Wellington, Waterloo, Oxford, Lambton, and Middlesex counties.

Several Indigenous communities reside in the sub-region or may have interests in the sub-region, including Aamjiwnaang First Nation, Bkejwanong (Walpole Island First Nation), Chippewas of Kettle and Stony Point, Chippewas of the Thames, Nawash First Nation, Saugeen First Nation, Historic Saugeen Métis, MNO Great Lakes Métis Council, Six Nations of the Grand River and Haudenosaunee Chiefs Confederacy Council.

The Scoping Assessment recommended a focused IRRP for the Southern Huron-Perth sub-region. This sub-region consists of the area supplied by the 115 kV circuit L7S, which includes municipalities of Bluewater, South Huron, Lambton Shores, Lucan-Biddulph, Middlesex Centre, North Middlesex, Thames Centre, Zorra, Perth South, Town of St. Marys, and West Perth. The approximate geographical boundaries of the sub-region are shown in Figure 1.1.

Figure 1.1 | Map of the Southern Huron-Perth Sub-Region

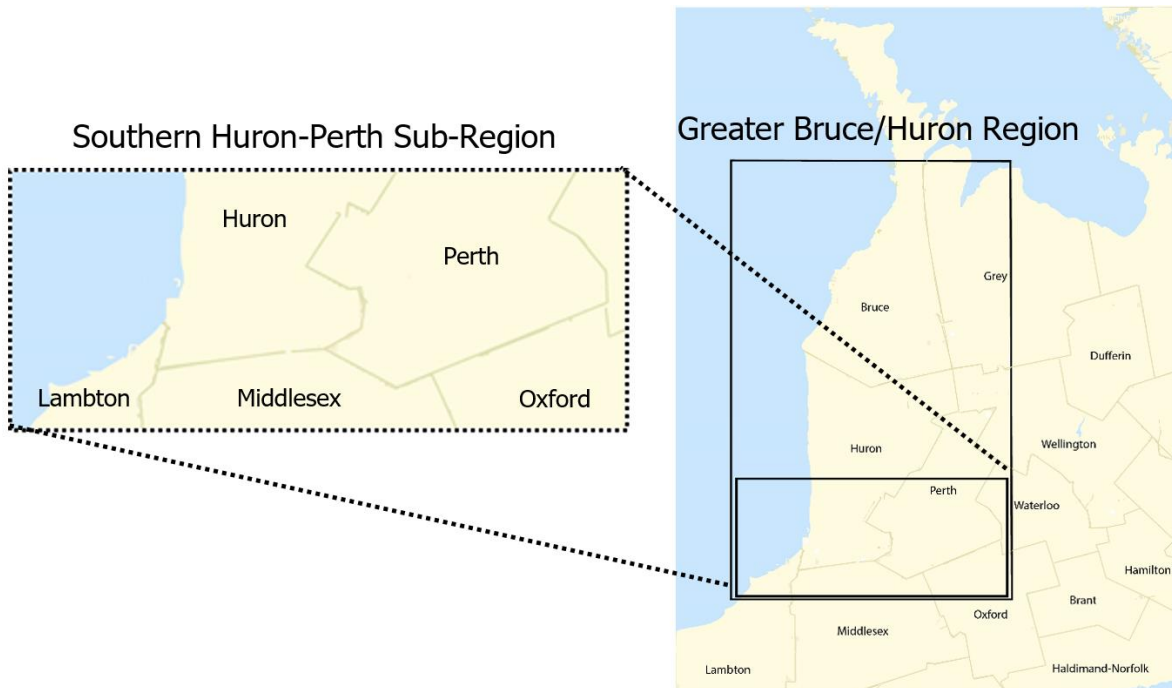

The Southern Huron-Perth sub-region is summer peaking and is served via 115 kV circuit L7S from Seaforth TS and a local wind farm. These facilities supply seven local load stations, including Centralia TS, Grand Bend East DS, St. Marys TS, and four customer transformer stations (CTS). The sub-region has an alternate supply point via 115 kV circuit D8S, which connects a portion of St. Marys TS to Detweiler TS in the adjacent Kitchener-Waterloo-Cambridge-Guelph region under normal operating conditions. The electrical system is illustrated in Figure 1.2 and the single line diagram in Figure 1.3.

Figure 1.2 | Electricity Infrastructure in the Southern Huron-Perth Sub-Region¹

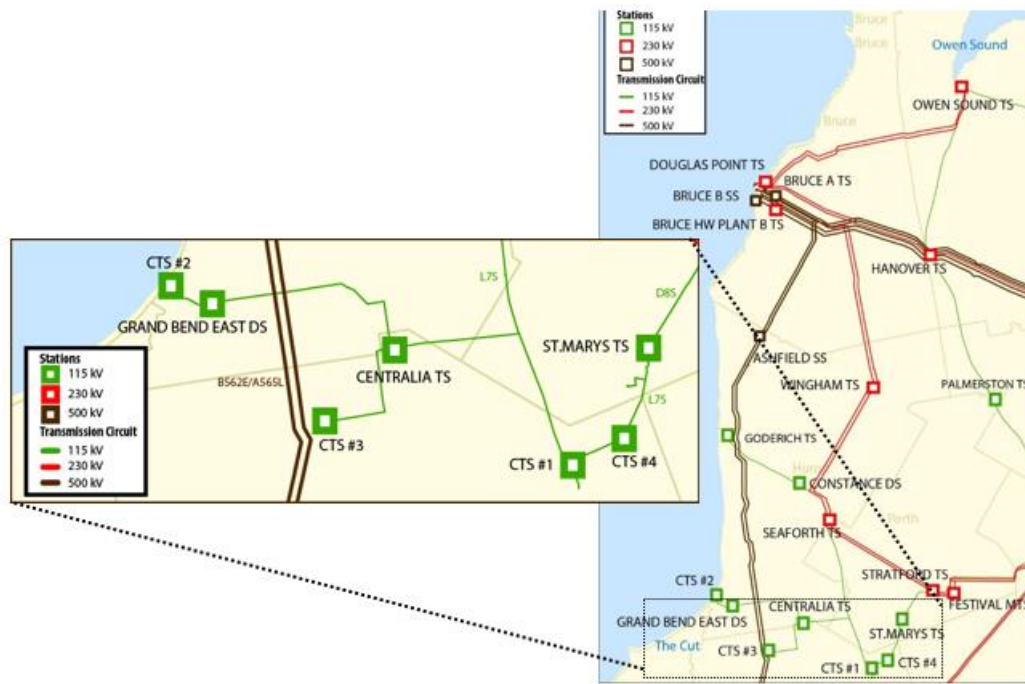
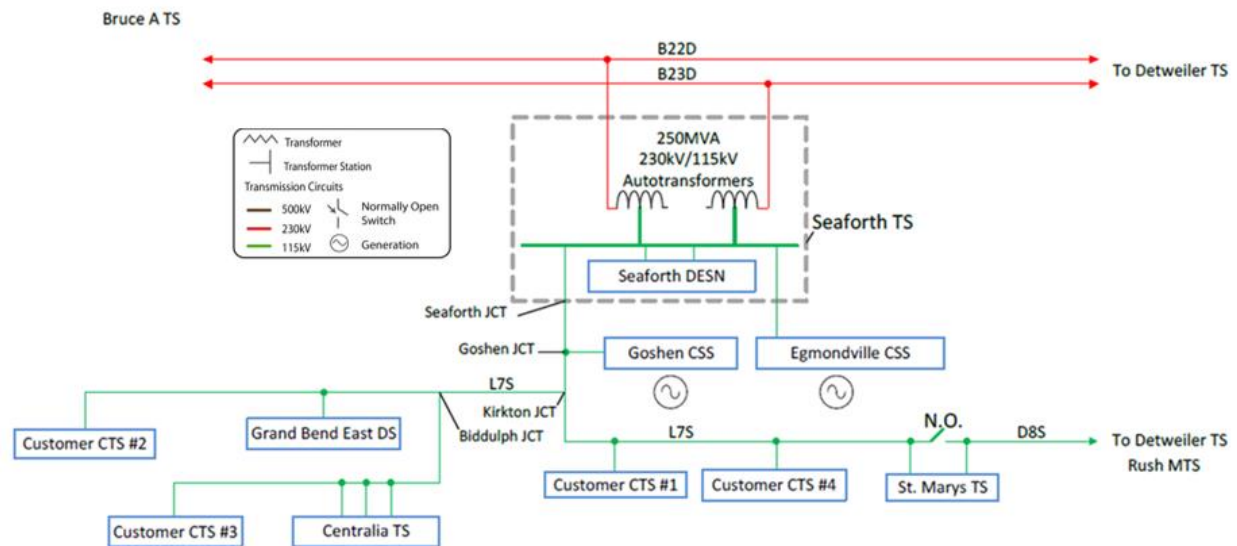

Figure 1.3 | Single Line Diagram of the Southern Huron-Perth Sub-Region, exclusive of the 230 kV system



Development of the Southern Huron-Perth IRRP was initiated in September 2019 following the publication of Hydro One’s Needs Assessment report on May 31, 2019 and, subsequently, the IESO’s Scoping Assessment Outcome Report and Terms of Reference on Sept 19, 2019, which identified needs that should be further assessed through an IRRP. The Working Group was then formed to gather data, identify near- to long-term needs in the region and develop the recommended actions included in this IRRP.

¹ The region is defined by electricity infrastructure; geographical boundaries are approximate.
Southern Huron-Perth IRRP, September 2021 | Public

In Ontario, planning to meet the electrical supply and reliability needs of a large area or region is carried out through regional electricity planning, a process that was formalized by the Ontario Energy Board (OEB) in 2013. In accordance with this process, transmitters, distributors and the IESO are required to carry out regional planning activities for 21 electricity planning regions across Ontario, including the Southern Huron-Perth sub-region, at least once every five years. The process allows a regional planning cycle to be triggered before the five-year mark due to material changes such as demand or resource changes. The active part of this cycle is made up of Needs Assessment, Scoping Assessment, IRRP, and Regional Infrastructure Plan (RIP) stages, which take up approximately half of the typical five-year timeframe. In many regions, this period of active planning is followed by a period when plan implementation begins, and the Working Group monitors demand trends until the next cycle begins. The complexity of issues requires the Working Group to continue to be engaged in integrated planning throughout the regional planning cycle, after the completion of the IRRP.

Further information on the process can be found in Appendix C. The IESO has also recently completed a review of the regional planning process following the completion of the first cycle of regional planning for all 21 regions. Additional information on the [Regional Planning Process Review](#) along with the final report is posted on the IESO's website.

The last regional planning cycle for the Greater Bruce/Huron region did not identify any needs requiring regional coordination and proceeded to three separate local plans, the last of which was concluded in May 2017, and was further consolidated and documented in a RIP for the region in August 2017, resulting in two recommendations which have since been completed. Those recommendations were: i) to install spacers and ground rods along the L7S circuit, and ii) to install motorized switches on L7S at Kirkton junction, Biddulph junction and St Marys TS, both of which are meant to enhance the delivery point performance for L7S and improve the performance reliability by reducing outage duration.

In addition to the needs reviewed in this IRRP for the Southern Huron-Perth sub-region, a few near-term end-of-life asset replacement needs were identified for the broader Greater Bruce/Huron region and proceeded to local planning. As well, an identified voltage issue at Hanover TS for the loss of 230 kV circuits B4V/B5V will be investigated in a subsequent bulk study. These outcomes were captured in the Greater Bruce/Huron Scoping Assessment.

This report is organized as follows:

- A summary of the recommended plan for the region is provided in Section 2;
- The process and methodology used to develop the plan are discussed in Section 3;
- The context for electricity planning in the region and the study scope are discussed in Section 4;
- Demand forecast scenarios, and conservation and demand management and distributed generation assumptions, are described in Section 5;
- Electricity needs in the region are presented in Section 6;
- Alternatives and recommendations for meeting needs are addressed in Section 7;
- A summary of engagement to date and moving forward is provided in Section 8; and
- A conclusion is provided in Section 0.

2 The Integrated Regional Resource Plan

The Southern Huron-Perth IRRP provides recommendations to address the electricity needs for the region over the next 20 years based on application of the IESO's Ontario Resource and Transmission Assessment Criteria (ORTAC). The needs were identified over three main planning horizons: from the base year when the forecast was originated (2019) through the near term (up to and including 2023), medium term (six to 10 years, from 2024 to 2028 inclusive), and long-term (11 to 20 years, or from 2029 to 2038). These planning horizons are distinguished in the IRRP to reflect the different levels of forecast certainty, lead time for development, and planning commitment required over these time horizons. The recommendations have been developed in consideration of a number of factors including reliability, cost, technical feasibility, environmental and social factors, and maximization of the use of the existing electricity system, where it is economic to do so.

The Needs Assessment identified a capacity need in this sub-region, however, given changes to customers' growth plans, the triggering loads for that need were deferred with no firm in-service date. In order to conduct a fulsome long-term plan, two forecast scenarios were developed and evaluated for the purposes of this IRRP: i) a Reference Scenario and ii) a High Growth Scenario. The Reference Scenario represents the firm load requests and projected residential and commercial growth, while the High Growth Scenario also includes the industrial loads initially projected, but shifted to the mid- to long-term to determine what may be required if/when that load materializes.

The following sections provide details of the needs and recommendations to address the identified need under both scenarios.

2.1 Reference Scenario Needs

Based on the IRRP load forecast and ongoing work in the area, no needs have been identified under the Reference Scenario.

2.2 High Growth Scenario Needs

While no needs have been identified under the Reference Scenario, potential long-term supply capacity needs were identified under the High Growth Scenario. In 2035, flows on circuit L7S exceed its thermal ratings following the loss of D8S, the 115 kV circuit from Detweiler TS to St Marys TS, which forms the only other supply circuit into the Southern Huron-Perth sub-region. Approximately, 11 MW of supply is needed to mitigate the overload. Considering outage conditions, in 2030, flows on L7S exceed its thermal ratings for the loss of Seaforth T6, one of the two autotransformers at Seaforth TS, under an outage to D8S. Both of these contingencies result in all loads within the Southern Huron-Perth sub-region being supplied via L7S.

A combination of conservation and demand management (CDM) beyond what is committed and planned through existing provincial and federal programs, along with distribution load transfers, could resolve the High Growth needs identified. These are both cost-effective measures that could be implemented within one to three years, as required. At this time, none of the supply capacity needs identified over the long term require early development work for major infrastructure projects in the Southern Huron-Perth sub-region. There may be opportunities for communities and local utilities to manage their future electricity demand through the development of community-based solutions that may evolve between planning cycles.

When load levels are within approximately 4 MW of the sub-region's supply capacity, projected to occur within the next 5 years based on the Reference scenario, CDM programs can be pursued and load transfers can be implemented to bridge any potential gap.

The Working Group will continue to monitor load growth in this area and re-evaluate these needs periodically, including in the next regional planning cycle, to take action as necessary when load tends towards the High Growth Scenario to ensure there are no reliability impacts.

Recognizing the most cost-effective solution involves additional conservation, the Working Group should also seek regulatory clarity on implementation mechanisms for this solution type in advance of the long-term need materializing, noting that multiple LDCs are supplied by the L7S circuit (i.e., would require clarification of approach if existing CDM Guidelines were to be leveraged for implementation) and the opportunity to leverage some existing mechanisms (i.e., the Local Initiatives Program) may or may not align with when the need materializes.

2.3 Conservation and Demand Management

Conservation is important in managing demand in Ontario and plays a key role in maximizing the utilization of existing infrastructure and maintaining a reliable supply of electricity.

As part of the reference forecast, conservation savings from codes and standards and the 2019-2020 CDM programs were accounted for, based on the best known information at the time.

Following the development of the planning forecast, on September 30, 2020 the IESO received a Ministerial directive to implement a new 2021-2024 CDM Framework, which follows the conclusion of the 2019-2020 Interim Framework. The new 2021-2024 CDM Framework will focus on cost-effectively meeting the needs of Ontario's electricity system, including by focusing on the achievement of provincial peak demand reductions, as well as targeted approaches to address regional and/or local electricity system needs. The savings that will be achieved through the 2021-2024 CDM Framework will help reduce supply capacity needs identified under the High Growth scenario.

In addition, there is the opportunity for up to 16.1 MW in further peak CDM savings that could be achieved in this sub-region, based on the [2019 Achievable Potential Study](#).

It is recommended that the Working Group monitor the progress of the 2021-2024 CDM Framework and the contribution of savings from its programs to reducing net demand in the region, and to explore the opportunity for participation in the Local Initiatives Program as an option to help address needs in the long term.

In addition, the IESO's Indigenous Community Energy Plan Program supports First Nation and Métis communities and organizations to develop and maintain an updated community energy plan designed to enhance community energy security. The IESO is also working with Indigenous communities to develop their community energy plan, which documents the communities' energy baseline and analyses and recommends efficiency and conservation measures and retrofits.

3 Development of the Plan

3.1 The Regional Planning Process

In Ontario, preparing to meet the electricity needs of customers at a regional level is achieved through regional planning. Regional planning assesses the interrelated needs of a region—defined by common electricity supply infrastructure—over the near, medium, and long term and results in a plan to ensure cost-effective, reliable electricity supply. A regional plan considers the existing electricity infrastructure in an area, forecast growth and customer reliability, evaluates options for addressing needs, and recommends actions.

The current regional planning process was formalized by the OEB in 2013 and is performed on a five-year planning cycle for each of the 21 planning regions in the province. The process is carried out by the IESO, in collaboration with the transmitters and LDCs in each planning region.

The process consists of four main components:

- A Needs Assessment, led by the transmitter, which completes an initial screening of a region's electricity needs and determines if there are electricity needs requiring regional coordination;
- A Scoping Assessment, led by the IESO, which identifies the appropriate planning approach for the identified needs and the scope of any recommended planning activities;
- An IRRP, led by the IESO, which proposes recommendations to meet the identified needs requiring coordinated planning; and/or
- A RIP, led by the transmitter, which provides further details on recommended wires solutions.

Further details on the regional planning process and the IESO's approach to regional planning can be found in Appendix C.

Regional planning is not the only type of electricity planning in Ontario. Other types include bulk system planning and distribution system planning. There are inherent overlaps in all three levels of electricity infrastructure planning.

The IESO has recently completed a review of the regional planning process following the completion of the first cycle of regional planning for all 21 regions. Additional information on the [Regional Planning Process Review](#) along with the final report is posted on the IESO's website.

3.2 Southern Huron-Perth and IRRP Development

The process to develop the Southern Huron-Perth IRRP was initiated following the release of the Needs Assessment report for the region by Hydro One in May 2019 and the subsequent Scoping Assessment report produced by the IESO in September 2019, which recommended needs identified for the Southern Huron-Perth sub-region be further pursued through an IRRP. This was due to the potential for coordinated solutions and non-wires alternatives. Shortly after, the Working Group was formed to develop terms of reference for the IRRP, gather data, identify near- to long-term needs in the area, and recommend near- to long-term solutions. In September 2020, the Scoping Assessment was revised and reissued to reflect changes to the study scope and timelines.

4 Background and Study Scope

This is the second cycle of regional planning for the Greater Bruce/Huron region. The first cycle of regional planning started in February 2016 with the Needs Assessment, and proceeded to local planning. In August 2016, a Regional Infrastructure Plan (RIP) was published that summarized findings from local planning, and reviewed new needs from updated load forecasts in the Kincardine area. The Local Planning Report and RIP recommended:

- Monitoring loading on L7S and increasing the emergency rating once loading approaches capacity;
- A two-stage plan (to install spacers and ground rods along the L7S circuit, and to install motorized switches on L7S) to reduce frequency and duration of interruptions due to adverse weather; and
- Monitoring load growth in the Kincardine area to identify any potential step-down transformation capacity needs at Douglas Point TS.

The 2019 Needs Assessment identified that under outage conditions, L7S – the 115 kV circuit that provides supply to Southern Huron-Perth through Seaforth TS – would be thermally overloaded by 2022, when the emergency rating will be exceeded with D8S out of service. Under all elements in service conditions, the circuit would be thermally overloaded by 2027. As such, Hydro One initiated a project to increase the sag clearance of limiting sections from Seaforth to Kirkton junction, scheduled for 2021/2022, which partly addressed the identified supply capacity need.

Even after Hydro One increases the sag clearance of the limiting section, there is still a remaining supply capacity need on L7S circuit requiring further regional coordination and, hence, an IRRP was initiated, focused on the Southern Huron-Perth sub-region. This report presents an integrated regional electricity plan for the next 20-year period starting from 2019.

4.1 Study Scope

This IRRP develops and recommends options to meet the supply needs of the Southern Huron-Perth sub-region in the near, medium, and long term. The plan was prepared by the IESO on behalf of the Working Group. The plan includes consideration of forecast electricity demand growth, CDM, DG, transmission and distribution system capability, relevant community plans, condition of transmission assets and developments on the bulk transmission system. The needs addressed in this IRRP include adequacy, security, and relevant end-of-life asset considerations.

The following transmission facilities were included in the scope of this study:

- **115 kV connected stations:** Seaforth TS, Grand Bend East DS, Centralia TS, St Marys TS and four customer-connected transformer stations;
- **115 kV transmission lines:** L7S, D8S; and
- **230/115 kV autotransformers:** Seaforth TS T1/T2.

Supply to the Southern Huron-Perth sub-region is provided from the broader Greater Bruce/Huron region through the autotransformers at Seaforth TS, which connect to the 115 kV circuit L7S, and the 115 kV circuit D8S, connected to the adjacent Kitchener/Waterloo/Cambridge/Guelph region through Detweiler TS.

The Southern Huron-Perth IRRP was developed by completing the following steps:

- Preparing a 20-year electricity demand forecast and establishing needs over this timeframe;
- Examining the load meeting capability (LMC) and reliability of the existing transmission system, taking into account facility ratings and performance of transmission elements, transformers, local generation, and other facilities such as reactive power devices. Needs were established by applying ORTAC;
- Assessing system needs by applying a contingency-based assessment and reliability performance standards for transmission supply in the IESO-controlled grid as described in Section 7 of ORTAC;
- Confirming identified end-of-life asset replacement needs and timing with transmission asset owners, along with other relevant asset demographic information;
- Establishing alternatives to address system needs, including, where feasible and applicable, possible energy efficiency, generation, transmission and/or distribution, and other approaches such as non-wires alternatives;
- Engaging with the community on needs, findings, and possible alternatives;
- Evaluating alternatives to address near- and long-term needs; and
- Communicating findings, conclusions, and recommendations within a detailed plan.

5 Electricity Demand Forecast

Regional planning in Ontario is driven by the need to meet peak electricity demand requirements in the region. This section describes the specific details of the development of the demand forecast for the Southern Huron-Perth sub-region. It highlights the assumptions made for peak demand forecasts, including the contribution of conservation and distributed generation (DG) to reducing peak demand. The resulting net demand forecast is used in assessing the electricity needs of the area over the planning horizon as explained in the next section.

To evaluate the adequacy of the electric system, the regional planning process involves measuring the demand observed at each station for the hour of the year when overall demand in the study area is at a maximum, also called the coincident peak demand. This differs from a non-coincident peak, which refers to each station’s individual peak, regardless of whether the stations’ peaks occur at different times. Within the Southern Huron-Perth sub-region, the peak loading hour for each year occurs in the summer.

5.1 Demand Forecast Methodology

For the purpose of this IRRP, a 20-year regional peak demand forecast was developed to assess supply and reliability needs for the Southern Huron-Perth sub-region. The steps taken to perform this are depicted in Figure 5.1. Gross demand forecasts, which assume the weather conditions of an average year based on historical data and referred to normal weather, were developed by the LDCs. These forecasts were then modified to reflect the peak demand impacts of the 2019-2020 provincial conservation programs and future savings from codes and standards, as well as DG contracted through provincial programs such as FIT and microFIT, and then adjusted to reflect extreme weather conditions in order to produce a reference forecast for planning assessments. This forecast was then used to assess the electricity needs in the region. Additional details related to the development of the demand forecast are provided in Appendix A.

Figure 5.1 | Development of Demand Forecast

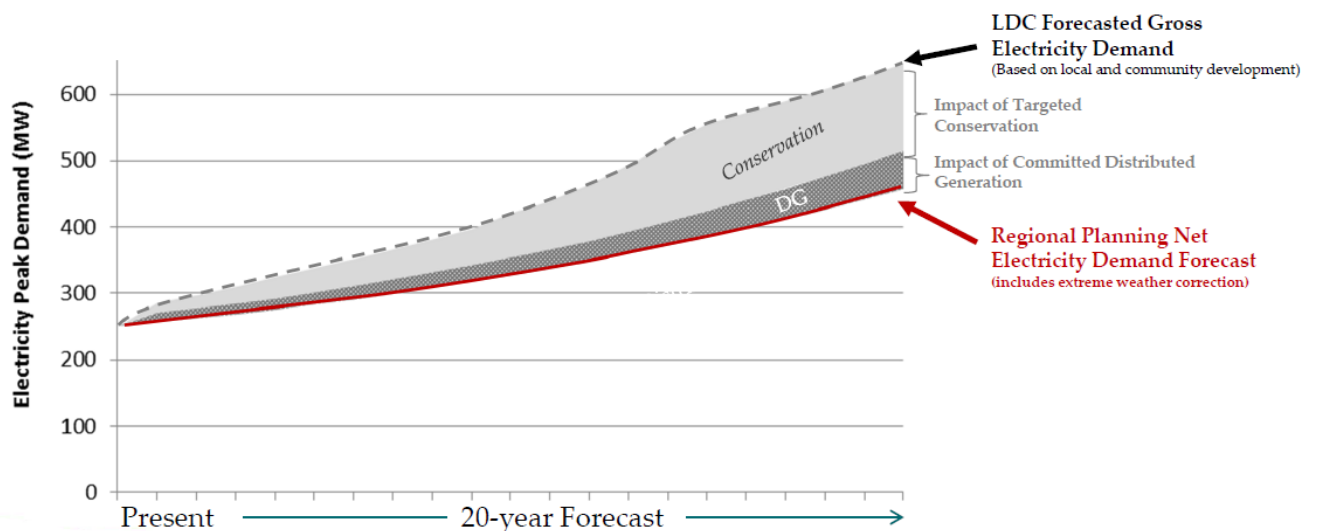

5.2 Historical Electricity Demand

The Southern Huron-Perth sub-region electricity demand is a mix of residential, commercial and industrial loads, encompassing diverse economic activities ranging from educational institutions to building materials manufacturing. While the industrial and commercial sector is the largest consumer of electricity, high-energy-consuming end uses such as air conditioning also play a significant role in contributing to peak electricity demand. During the summer months, peak demand can also be influenced by extreme weather conditions, with peaks in demand typically occurring after several days of high temperatures. More recently, there has been a shift towards increased residential growth in various parts of the sub-region, primarily driven from nearby urban centers (City of London, Region of Waterloo and City of Guelph), stemming from workplace flexibility as a result of the COVID-19 pandemic.

As shown in Figure 5.2, the historical summer peak demand has fluctuated between 100 MW to 120 MW in the recent years. This figure also shows the weather corrected net and gross coincident peak demand for normal weather. The gross demands on the station level in 2018 were the reference starting points for LDCs to forecast their 20-year gross demand as discussed in the next section. Note, the net measure load in 2018 was significantly higher than expected, driven by unseasonably hot summer conditions resulting in higher campground and trailer park load over the Canada Day long weekend, as well as load that was transferred to Grand Bend East DS. This was accounted for through the weather correction and an adjustment made to the reference starting point to account for the load transfer.

Figure 5.2 | Measured & Weather Corrected Coincident Net and Gross Historical Peak Demand in the Southern Huron-Perth sub-region

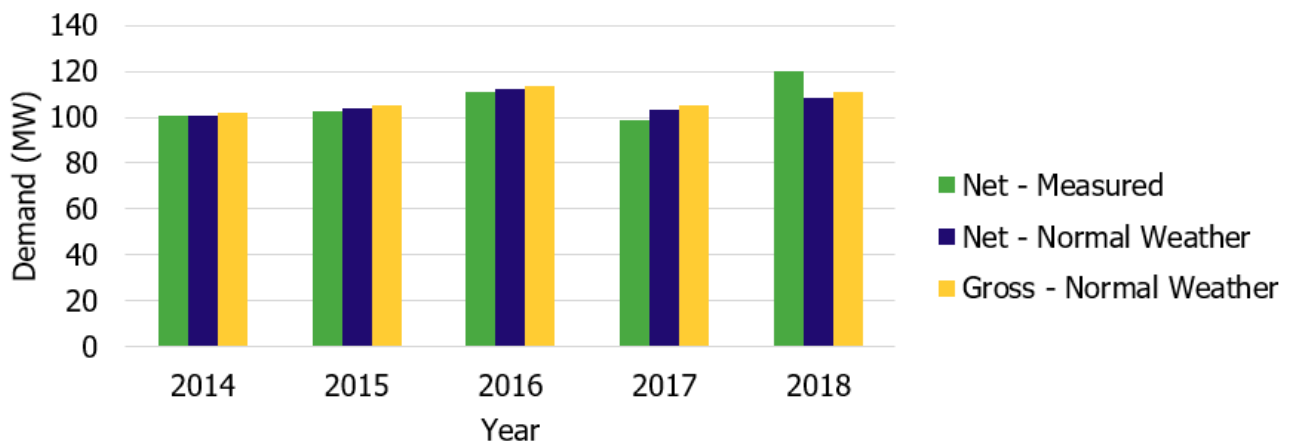

5.3 Gross and Net Demand Forecast

Each participating LDC in the Southern Huron-Perth sub-region prepared gross non-coincident demand forecasts at the station level, or at the station bus level for multi-bus stations. Gross demand forecasts account for increases in demand from new or intensified development. LDCs are expected to account for changes in consumer demand resulting from typical efficiency improvements and response to increasing electricity prices, or “natural conservation”, but not for the impact of future DG or new conservation measures, such as codes and standards and conservation programs, which will be accounted for by the IESO as discussed in Section 5.1.

LDCs have the best information on customer and regional growth expectations in the near and medium term, since they have the most direct involvement with their customers. Most LDCs cited alignment with municipal and regional official plans as a primary source for input data. Other common considerations included known connection applications and typical electrical demand for similar customer types. More details on the LDCs’ load forecast assumptions can be found in Appendix A.

Figure 5.3 shows the total gross non-coincident demand forecast in the next 20 years as provided by LDCs, based on the IESO’s reference point for normal weather. Figure 5.3 also shows the net non-coincident normal weather forecast compiled by the IESO, which accounts for the impacts of conservation and DG on peak demand, along with the IESO’s net non-coincident demand forecasts corrected to extreme weather, referred to as the planning demand forecast, used for the assessments in the IRRP. This was then converted to a coincident forecast using coincidence factors from the base year (2018). The contribution of conservation and DG to the planning demand forecast is discussed in the following sections.

Figure 5.3 | Normal/Extreme Weather Corrected Coincident Net and Gross Peak Demand in the Southern Huron-Perth sub-region

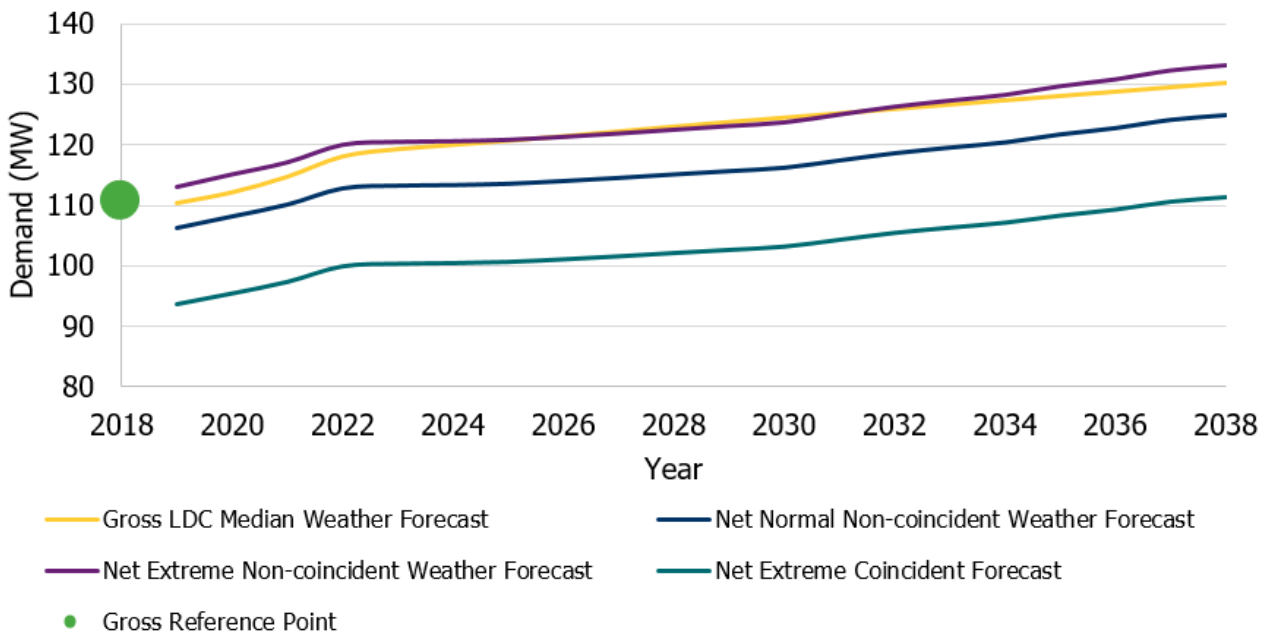

5.4 Contribution of Conservation to the Forecast

Conservation is a clean and cost effective resource for helping to meet Ontario's electricity needs and has been an integral part of ensuring a reliable and sustainable electricity system in provincial and regional planning. Conservation is achieved through a mix of program-related activities, and mandated efficiencies from building codes and equipment standards. These approaches complement each other to maximize conservation results.

The following section describes the conservation assumptions included in the forecast. These include savings due to codes and standards, and IESO-delivered conservation programs in 2019 and 2020.²

The estimates of demand reduction due to the codes and standards are based on the expected improvement in the codes for new and renovated buildings and for specified categories of consumers, i.e. residential, commercial and industrial, through the regulation of minimum efficiency standards for equipment.

The IESO centrally delivers programs on a province wide basis to serve business and low-income customers, as well as Indigenous communities. [Save on Energy](#) programs will result in new savings, reducing energy and peak demand in the sub-region. The forecast included savings achieved through the wind-down of 2015-2020 Conservation First Framework and the 2019-2020 Interim Framework. While these programs are not targeted to a given area, it is assumed that a portion of participation will occur in the sub-region. Savings associated to large transmission-connected industrial loads are highly dependent on actions by the individual customers.

Zonal average CDM savings for industrial loads amalgamate savings across a diverse range of industries. As such, the zonal average may not be completely representative of industrial savings on a more localized scale, such as within Southern Huron-Perth which may not align with that industrial loads mixture. Thus, the conservation savings for large industrial customers were based on known conservation initiatives being undertaken by these customers rather than estimated based on the zonal average.

Figure 5.4 shows the yearly estimate of the reduction to the demand forecast due to conservation for each of the residential, commercial and industrial consumers. As shown, conservation in the residential sector accounts for the largest contribution. Additional details are provided in Appendix A.

² Includes savings achieved through the wind-down of 2015-2020 Conservation First Framework and the 2019-2020 Interim Framework. Southern Huron-Perth IRRP, September 2021 | Public

Figure 5.4 | Reduction to Demand Forecast due to Conservation by Sector (2019-2020 CDM Framework, 2015-2020 Conservation First Framework and Codes and Standards)

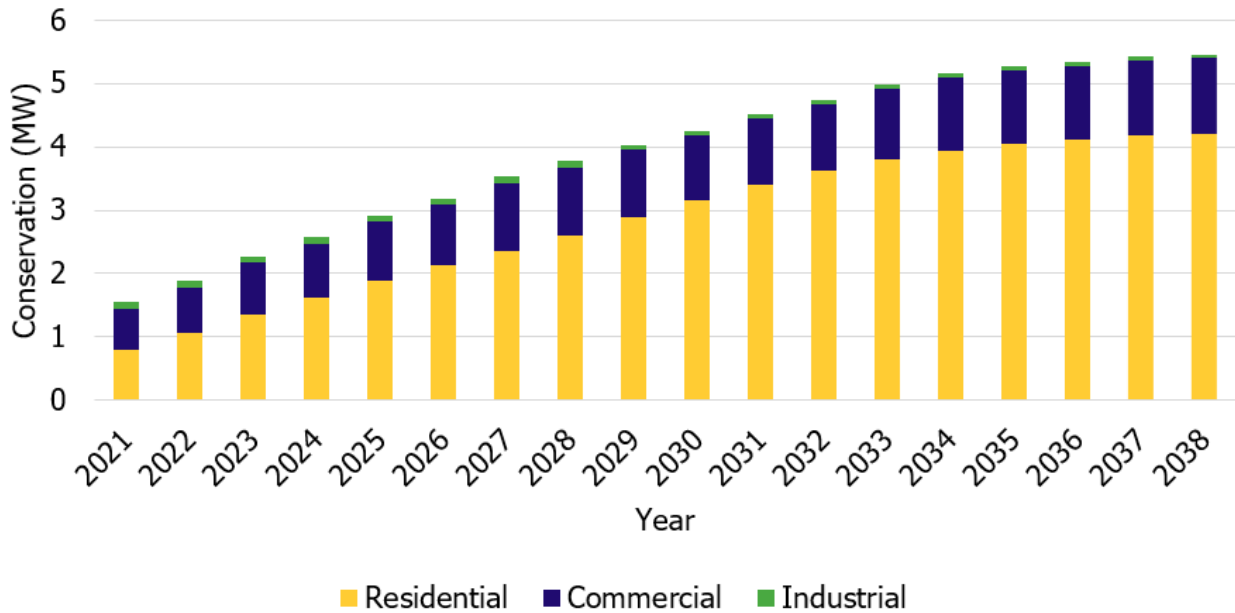
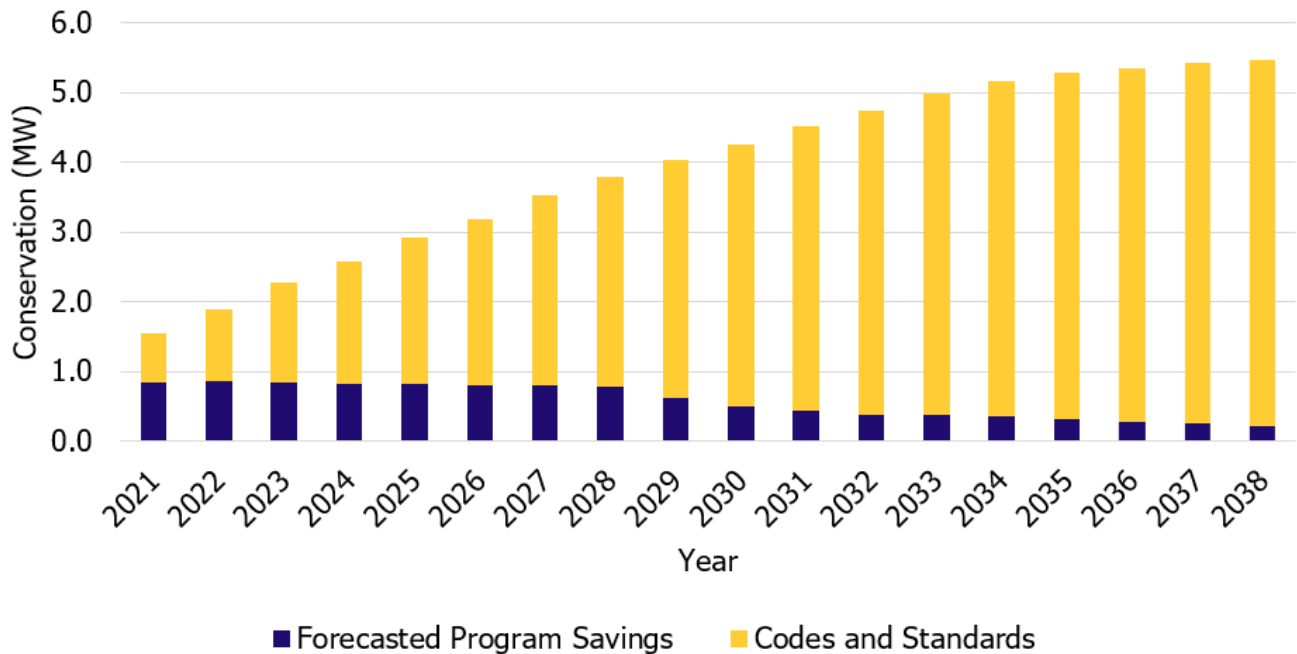

Figure 5.5 shows the yearly estimate of the reduction to the demand forecast due to conservation broken down by regulations and programs. As shown, codes and standards account for the largest contribution to conservation savings in this sub-region. The savings associated with the conservation programs considered in the forecast peaked in 2019-2020 – the target years for the Interim Framework – after which, savings begin to diminish as the conservation measures approach their effective useful life.

Figure 5.5 | Reduction to Demand Forecast due to Conservation by Program



On September 30, 2020 the IESO received a Ministerial directive to implement a new 2021-2024 CDM Framework starting in January 2021. As this directive was received after the Southern Huron-Perth sub-region’s load forecast was finalized its impact is not included in the forecast nor the above figure. However, it was factored into the conservation calculations during the options analysis in Section 7.

5.5 Contribution of Distributed Generation to the Forecast

In addition to conservation resources, DG in the Southern Huron-Perth sub-region is also forecast to offset peak-demand requirements. The introduction of the Green Energy and Green Economy Act, 2009, and the associated development of Ontario’s past FIT Program, has increased the significance of distributed renewable generation which, while intermittent, contributes to meeting the province’s electricity demands.

After reducing the demand forecast due to conservation as described above, the forecast is further reduced by the expected contribution from contracted DG in the region.

Figure 5.6 shows the combined impact of the conservation and DG on reducing the demand forecast. In the long term, as the DG contribution diminishes due to contract expiry, conservation further contributes to reducing the demand and as a result the combined impact remains relatively constant.

Figure 5.6 | Reduction to Demand Forecast due to DG and Conservation

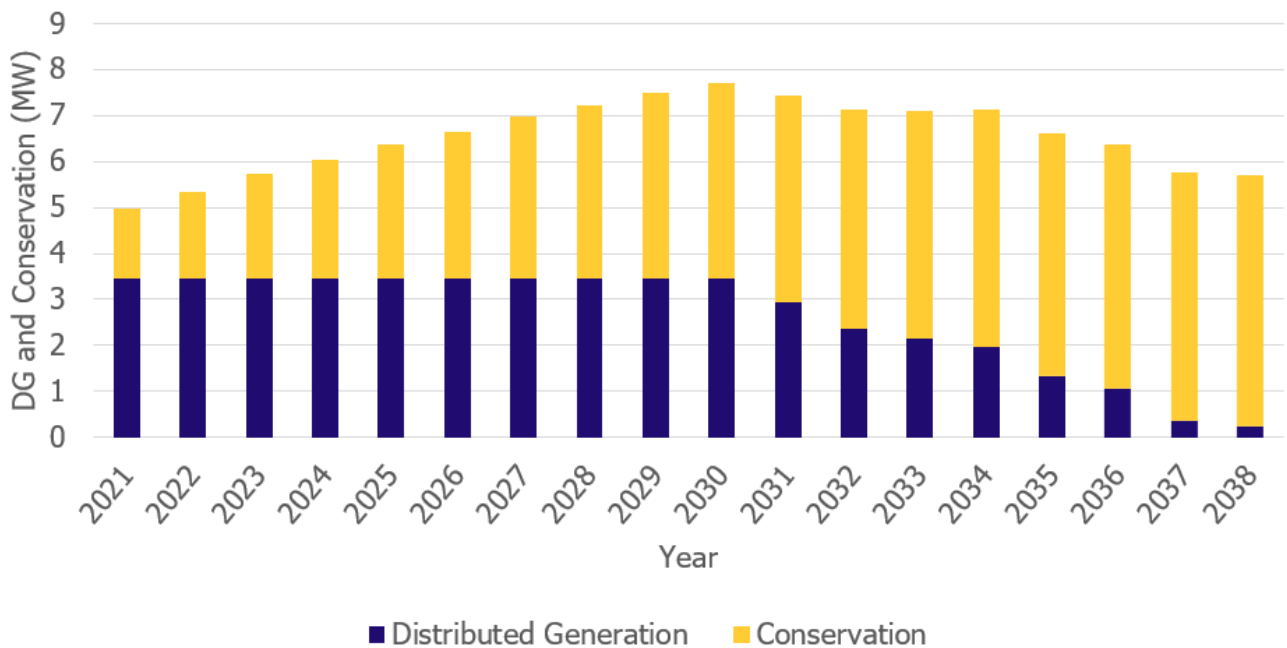

Note that any facilities without a contract are not currently included in the DG forecast.

5.6 Demand Forecast Scenarios

During the Needs Assessment, a significant industrial load project was expected in the sub-region, resulting in anticipated supply capacity needs. When the forecast was refined within the IRRP process, that industrial load project was deferred for at least five years, but with no firm target date. As well, subsequent updates received from stakeholders and communities have indicated there may be unforeseen impacts to the sub-region’s demand as the COVID-19 pandemic has changed the way many people live and work.

In order to conduct a comprehensive assessment to identify solutions to address a supply capacity need, if/when the load growth materializes, two forecast scenarios were created:

- Reference Scenario: Following the process described in Section 5.1; and
- High Growth Scenario: The Reference Scenario, with additional 8 MW blocks of industrial growth every five years, starting in 2025.
- The intent of this approach is to identify actions required to address the reference scenario needs, and establish a plan to address the High Growth Scenario needs should they materialize, including if there are near-term actions required to maintain those long-term options. While the impetus for developing a High Growth Scenario was based on projected industrial load growth, this scenario also serves to understand what may be required if and when further load growth materializes, irrespective of the load growth driver.

The two planning forecast scenarios are shown in Figure 5.7, along with what was previously estimated in the 2019 Greater Bruce/Huron Needs Assessment.

Figure 5.7 | Demand Forecast Scenarios

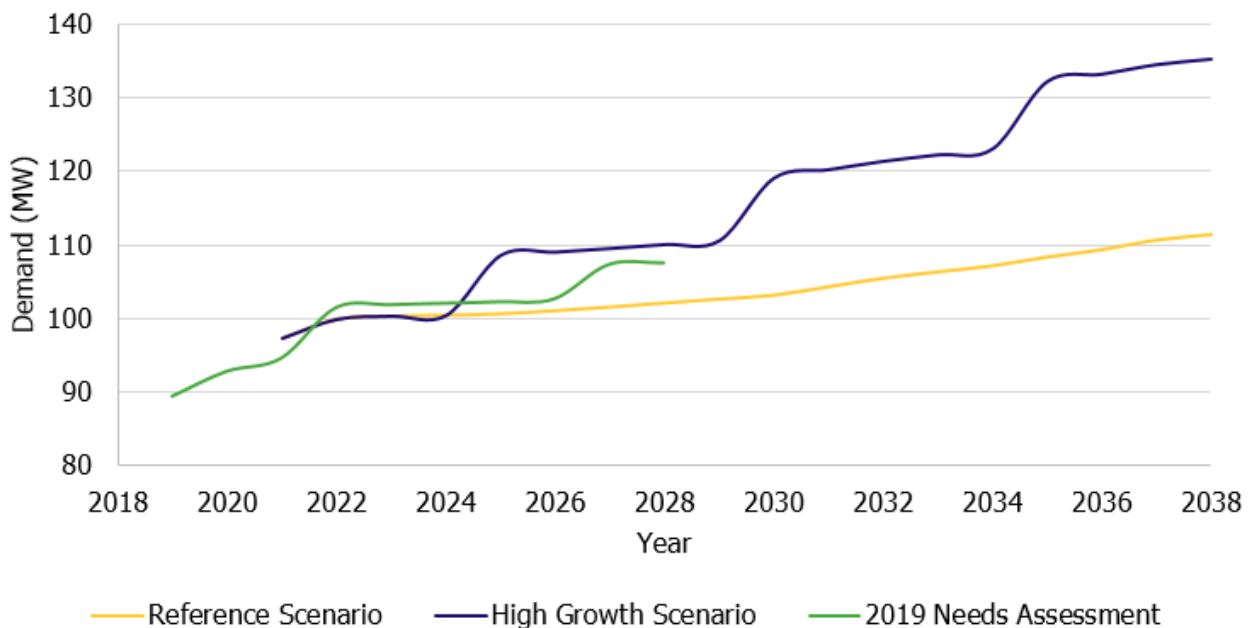

5.7 Project to Consider for Next Cycle

The industrial load expansion project identified in the Needs Assessment was not accounted for in the Reference load forecast during this IRRP cycle because the in-service date was subsequently deferred and so it did not have a confirmed status or connection point. They were modelled in the High Growth Scenario, to outline actions that would be required to address needs if and when the load growth materialized. The Working Group will continue to monitor the situation and if required, a new IRRP cycle or addendum will be launched.

6 Needs

6.1 Needs Assessment Methodology

Based on the planning demand forecast (extreme weather, net demand), system capability, the transmitter's identified end-of-life asset replacement plans, and the application of [ORTAC](#) and North American Electric Reliability Corporation (NERC) [TPL 001-4 Standard](#), the Working Group assessed electricity needs in the near-, medium- and long-term timeframe for the following categories:

- **Station Capacity Needs** describe the electricity system's inability to deliver power to the local distribution network through the regional step-down transformer stations at peak demand. The capacity rating of a transformer station is the maximum demand that can be supplied by the station and is limited by station equipment. Station ratings are often determined based on the 10-day LTR of a station's smallest transformer under the assumption that the largest transformer is out of service. A transformer station can also be limited when downstream or upstream equipment, e.g., breakers, disconnect switches, low-voltage bus or high voltage circuits, is undersized relative to the transformer rating.
- **Supply Capacity Needs** describe the electricity system's inability to provide continuous supply to a local area at peak demand. This is limited by the LMC of the transmission supply to an area. The LMC is determined by evaluating the maximum demand that can be supplied to an area accounting for limitations of the transmission elements, e.g., a transmission line, group of lines, or autotransformer, when subjected to contingencies and criteria prescribed by ORTAC and TPL 001-4. LMC studies are conducted using power system simulations analysis.
- **Load Security and Restoration Needs** describe the electricity system's inability to minimize the impact of potential supply interruptions to customers in the event of a major transmission outage, such as an outage on a double-circuit tower line resulting in the loss of both circuits. Load security describes the total amount of electricity supply that would be interrupted in the event of a major transmission outage. Load restoration describes the electricity system's ability to restore power to those affected by a major transmission outage within reasonable timeframes. The specific load security and restoration requirements are prescribed by Section 7 of ORTAC.
- **End-of-life Asset Replacement Needs** are identified by the transmitter with consideration to a variety of factors such as asset age, the asset's expected service life, risk associated with the failure of the asset, and its condition. Replacement needs identified in the near- and early mid-term timeframe would typically reflect more condition-based information, while replacement needs identified in the medium to long term are often based asset demographics (e.g. equipment age). As such, any recommendations for medium- to long-term needs should reflect the potential for the need date to change as condition information is routinely updated.

6.2 Needs Identified

The system was analyzed for all in-service conditions and single element contingencies, according to planning standards applicable to this sub-region. Within the Southern Huron-Perth sub-region, no needs were identified under the Reference Scenario, however, long-term supply capacity needs were observed under the High Growth Scenario for the Southern Huron-Perth sub-region. The needs are listed below:

- Possible long-term supply capacity needs under the High Growth Scenario on L7S, the 115 kV circuit from Seaforth TS, following the loss of 115 kV circuit D8S, of up to 11 MW by 2035; and
- Possible long-term supply capacity needs under the High Growth Scenario on L7S following the loss of Seaforth T6 with a prior outage on D8S, of up to 21 MW by 2030.

These supply capacity needs are limited by the same section of L7S circuit, as illustrated in Figure 6.1. As such these supply capacity needs overlap and are not cumulative.

Figure 6.1 | Needs Identified for the Southern Huron-Perth sub-region

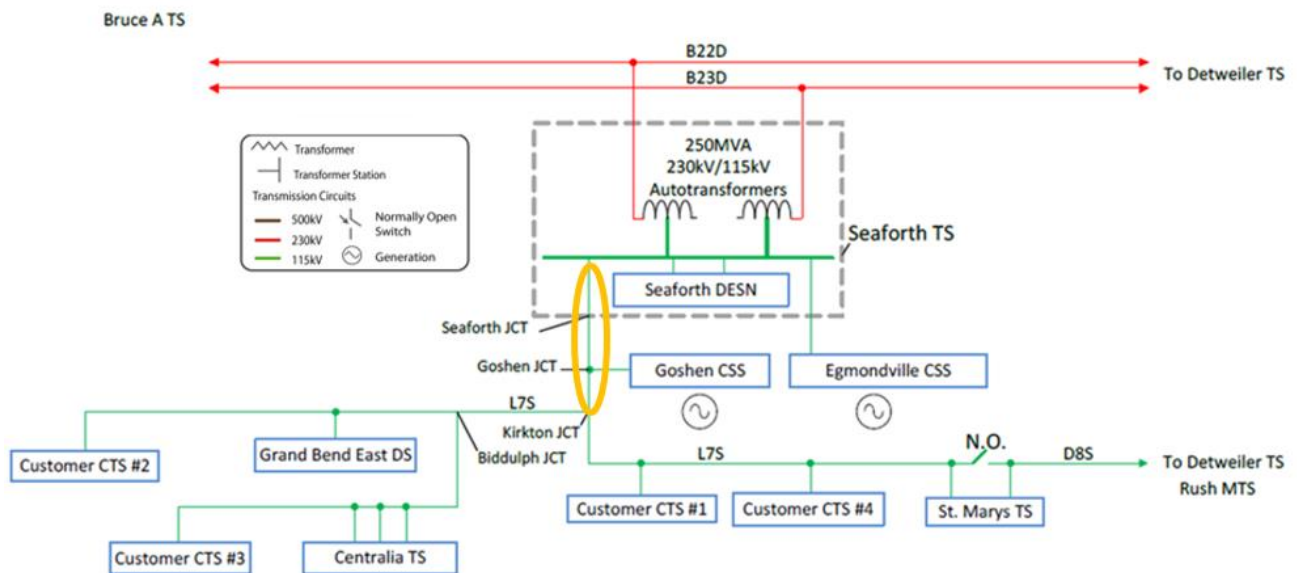

7 Plan Options and Recommendations

In developing the plan, the Working Group considered a range of integrated options. Considerations in assessing alternatives included maximizing use of existing infrastructure, provincial electricity policy, feasibility, cost, and consistency with longer-term needs in the area.

7.1 Long-term Needs

A potential long-term supply capacity need emerging in 2035, reaching 11 MW by 2038, was identified on L7S under the High Growth Scenario, following the loss of D8S. Under outage conditions to D8S, the supply need emerging in 2030, reaching 21 MW by 2038, was identified on L7S under the High Growth Scenario, following the loss of Seaforth T6.

The following sections outline the three main options considered to alleviate the potential supply capacity need:

- Load Transfers;
- Conservation and Demand Management; and
- L7S circuit upgrade.

Further details are provided in Appendix B.

Load Transfer

There is the ability to transfer up to 4.4 MW of load from Centralia TS to Seaforth TS, which is upstream of the limiting L7S supply circuit. This would cost approximately \$6-12M for distribution buildout. While this would not alleviate the entire supply capacity need, it would defer the High Growth Scenario need until 2035 and could be achieved in a short period of time, i.e. within the year.

Conservation

Conservation is important in managing demand in Ontario and plays a key role in maximizing the useful life of existing infrastructure and maintaining reliable supply. The IESO is mandated to centrally deliver province-wide conservation and demand management programs for Ontario that target businesses, select residential customers and First Nations communities. The IESO offers incentives and rebates to electricity customers through a suite of Save on Energy programs, which provide a valuable and cost-effective system resource that helps customers better manage their energy costs.

Conservation savings that are expected to be achieved through codes and standards and IESO programs delivered in 2019 and 2020, have already been included in the planning forecast scenarios as described in Section Contribution of Conservation to the Forecast5.4.

Since the reference forecast for this IRRP was developed, new energy efficiency programs have been planned beyond 2020 by both federal and Ontario agencies, including the new 2021-2024 CDM Framework. The IESO's new 2021-2024 CDM Framework will contribute to lowering the net demand as seen on the transmission system and ensure energy efficiency can continue to play a role in meeting the sub-region's needs.

The delivery of the new CDM framework and new federal programs will result in planned reductions in net demand in the region beyond what was included in the forecast. These programs are expected to deliver 0.6 MW of planned savings under the High Growth Scenario by 2038, the end of the study period.³

Beyond the forecasted savings expected from the 2021-2024 CDM Framework and new federal programs, there is the potential for further demand reductions from conservation activities. In 2019, the IESO completed an integrated electricity and natural gas conservation [Achievable Potential Study](#) in partnership with the Ontario Energy Board. The 2019 Achievable Potential Study identified significant and sustained potential for conservation across all customer sectors throughout the study period. The study results were used to estimate uncommitted conservation opportunities within the Southern Huron-Perth sub-region that are cost effective from the system perspective (i.e., whether the incentive costs are outweighed by the benefits to the electricity system) and not already committed to be delivered under the 2021-2024 CDM Framework and federal programs. Some value is attributed to non-energy benefits, such as customer comfort or improved business productivity.

Based on the demand forecasted under the High Growth Scenario for this region, the total expected achievable potential for conservation savings that is cost effective to the system is 16.7 MW by 2038, as illustrated in Figure 7.1. An estimated 0.6 MW of this potential is expected to be achieved through the 2021-2024 CDM Framework and federal programs. Thus, there is 16.1 MW of uncommitted potential by 2038 under the High Growth Scenario. Implementing both committed and uncommitted savings would defer the need until 2035, for an estimated program cost of \$26M, net present value. Although the cost is \$26M, for the purpose of this non-wires options assessment a cost of \$0 was assumed because these conservation savings are cost-effective to the system, meaning that there is a net benefit when comparing the program investment (cost) against the provincial average avoided costs of providing electricity (benefit).

³ Similar to the forecasted conservation savings described in Section 5.5, savings expected under this program peak during the target program years, reaching up to 2.2 MW.

Figure 7.1 | CDM Savings Potential under the High Growth Scenario

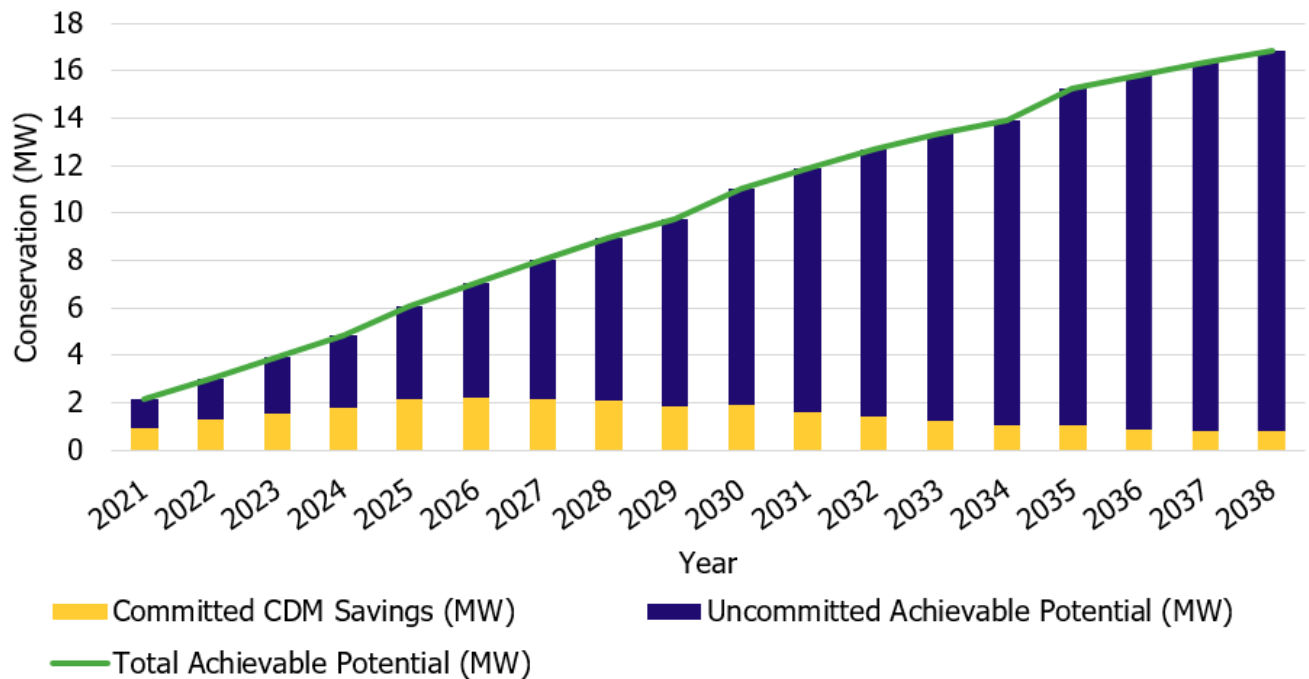

Note, unlike the savings assumed in the forecast in Section 5.5, this does include potential CDM savings for the forecast industrial loads. Since the zonal average may not be completely representative of industrial savings on a more localized scale, conversations with the new industrial load customers may be required to better understand planned CDM activities. Excluding the savings associated to the new industrial loads,⁴ the total achievable potential is 14.8 MW, approximately 14 MW of which is uncommitted.

The Local Initiatives Program (LIP) under the 2021-2024 CDM Framework can target CDM programs to regional and/or local areas to address local supply issues, in addition to, provincial supply issues. The IESO should explore options to target cost effective uncommitted savings to this area using the LIP and other mechanisms.

There are other potential benefits to non-wires investments, such as customer cost savings and reducing GHG emissions. As some of these other objectives may align with municipal energy plans in the sub-region, this may be useful input for identifying the potential for projects and strategies at the local level, while identifying where electrical system benefits and infrastructure deferral value may also exist.

⁴ Note, the forecasts for existing transmission-connected industrial customers are calculated based on known CDM activities specific to those facilities, rather than using the zonal averages. Refer to Appendix A.5 for further details.
Southern Huron-Perth IRRP, September 2021 | Public

Transmission Upgrade

The final option considered was upgrading the L7S circuit. While reconductoring would only be required for the limiting section of L7S (between Seaforth TS and Kirkton JCT), this would require installation of new poles along the whole section. While this would provide 50 MW of capacity, more than meeting the supply need identified, it would take 4-5 years, and would cost \$10-15M.

Recommendation

While the first two options cannot fully mitigate the High Growth Scenario needs individually, in combination, load transfers and CDM can address the identified need for a total cost of \$6-12M and together represent the most cost-effective option. If CDM measures change, this combined option would still provide sufficient lead time to trigger an L7S upgrade, as required. When load levels are within approximately 4 MW of the sub-region's supply capacity, projected to occur within the next 5 years based on the Reference scenario, CDM programs can be pursued and load transfers can be implemented to bridge any potential gap.

Since the appropriate solution for this need is highly dependent on future electricity demand growth, namely the timing and magnitude of the projected industrial load described in Section 5, it is recommended to continue monitoring the situation and devise an appropriate solution when any new demand growth and associated future developments are sufficiently certain.

There may be opportunities for the Working Group to work with communities and local utilities to manage future electricity demand through the development of community-based solutions under the IESO's new CDM Framework, the Indigenous Community Energy Plan Program, or other mechanisms or opportunities that may evolve between planning cycles.

The IESO will monitor the situation and explore long-term solutions with the Working Group and communities, as appropriate, if the need can no longer be addressed without impacting reliability.

8 Engagement

Engagement is critical in the development of an IRRP. Providing opportunities for input in the regional planning process enables the views and preferences of communities to be considered in the development of the plan, and helps lay the foundation for successful implementation. This section outlines the engagement principles as well as the activities undertaken to date for the Southern Huron-Perth IRRP.

8.1 Engagement Principles

The IESO's [engagement principles](#) help ensure that all interested parties are aware of and can contribute to the development of this IRRP. The IESO uses these principles to ensure inclusiveness, sincerity, respect and fairness in its engagements, striving to build trusting relationships as a result.

Figure 8.1 | The IESO's Engagement Principles



8.2 Creating an Engagement Approach for Southern Huron-Perth

The first step in ensuring that any IRRP reflects the needs of community members and interested stakeholders is to create an engagement plan to ensure that all interested parties understand the scope of the IRRP and are adequately informed about the background and issues in order to provide meaningful input on the development of the IRRP for the region.

- Creating the engagement plan for this IRRP involved:
- Targeted discussions to help inform the engagement approach for the planning cycle;
- Developing and implementing engagement tactics to allow for the widest communication of the IESO's planning messages, using multiple channels to reach audiences; and

- Identifying specific stakeholders and communities that should be targeted for one-on-one consultation, based on identified and specific needs.

As a result, the [engagement plan](#) for this IRRP included:

- A [dedicated webpage](#) on the IESO website to post all meeting materials, feedback received and IESO responses to the feedback throughout the engagement process;
- Regular communication with interested communities and stakeholders by email or through the IESO weekly Bulletin;
- Public webinars;
- Face-to-face meetings; and
- One-on-one outreach with specific stakeholders to ensure that their identified needs are addressed (see Section 8.3).

8.3 Engage Early and Often

The IESO held preliminary discussions to help inform the engagement approach for this new round of planning and establish new relationships with communities and stakeholders in the region.

An invitation was sent to targeted municipalities, Indigenous communities and those with an identified interest in regional issues to announce the commencement of a new regional planning cycle and invite interested parties to provide input on the draft Greater Bruce/Huron Scoping Assessment Report before it was finalized. Community feedback was received on increased expected economic development being driven by high growth in nearby urban centers such as the City of London that is pushing into areas such as Lucan-Biddulph and West Perth, as well as increased growth in agricultural, residential and industrial developments.

Following a written comment window, the final Scoping Assessment Outcome Report was published in September 2019 that identified the need for a coordinated planning approach done through an IRRP for the Southern Huron-Perth sub-region.

Following these initial discussions and finalization of the Scoping Assessment, the launch of a broader engagement initiative followed with an invitation to subscribers of the Greater Bruce/Huron region to ensure that all interested parties were made aware of this opportunity for input. Two public webinars were held at major junctures during IRRP development to give interested parties an opportunity to hear about its progress and provide comments on key components. Both webinars received strong participation with cross-representation of stakeholders and community representatives attending the webinar, and submitting written feedback during a 21-day comment period.

The two stages of engagement invited input on:

1. The draft engagement plan, the electricity demand forecast and the early identified needs to set the foundation of this planning work
2. The defined electricity needs for the sub-region, options evaluation and draft IRRP recommendations

All interested parties were kept informed throughout this engagement initiative via email to Greater Bruce/Huron region subscribers, municipalities and communities as well as the members of the [Southwest Regional Electricity Network](#).

Based on the discussions both through the Southern Huron-Perth IRRP engagement initiative and broader network dialogue, it is clear that there is broad interest in several Southwestern Ontario communities to further discuss the potential for solutions that incorporate non-wires alternatives. The long-term nature of the Southern Huron-Perth sub-region's potential future electricity needs presents a valuable opportunity for communities to mobilize projects and initiatives to meet local growth targets and energy priorities. To that end, ongoing discussions will continue through the IESO's Southwest Regional Electricity Network to keep interested parties engaged on local developments, priorities and planning initiatives.

All background information, including engagement presentations, recorded webinars, detailed feedback submissions, and responses to comments received, are available on the IESO's Southern Huron-Perth IRRP engagement [webpage](#).

8.4 Bringing Communities to the Table

The IESO held meetings with communities to seek input on their planning and to ensure that these plans were taken into consideration in the development of this IRRP. At major milestones in the IRRP process, meetings with the upper- and lower-tier municipalities in the region were held to discuss: key issues of concern, including forecast regional electricity needs; options for meeting the region's future needs; and, broader community engagement. These meetings helped to inform the municipal/community electricity needs and provided opportunities to strengthen this relationship for ongoing dialogue beyond this IRRP process.

8.5 Engaging with Indigenous Communities

To raise awareness about the regional planning activities underway and invite participation in the engagement process, regular outreach was made to Indigenous communities within the Southern Huron-Perth electricity planning sub-region or that may have interests in the sub-region throughout the development of the plan. This includes the communities of Aamjiwnaang First Nation, Bkejwanong (Walpole Island First Nation), Chippewas of Kettle and Stony Point, Chippewas of the Thames, Nawash First Nation, Saugeen First Nation, Historic Saugeen Métis, MNO Great Lakes Métis Council, Six Nations of the Grand River and Haudenosaunee Chiefs Confederacy Council. Further, the IESO endeavoured to identify opportunities for energy projects and initiatives in Indigenous Community Energy Plans for consideration in the long-term electricity planning for the Southern Huron-Perth sub-region. The IESO remains committed to an ongoing, effective dialogue with communities to help shape long-term planning in regions all across Ontario.



9 Conclusion

This report documents an IRRP that has been developed for the Southern Huron-Perth sub-region, and identifies regional electricity needs and opportunities to preserve or enhance electricity system reliability for the next 20 years. While no needs have been identified under the Reference Scenario, the IRRP lays out actions to monitor, defer, and address long-term needs projected under the High Growth Scenario.

To support the development of the plan, this IRRP includes recommendations with respect to monitoring load growth and efficiency achievements, such as through local initiatives and the Indigenous Community Energy Plan Program. Responsibility for these actions has been assigned to the appropriate members of the Working Group.

The Working Group will continue to meet at regular intervals to monitor developments and track progress toward plan deliverables. In the event that underlying assumptions change significantly, local plans may be revisited through an amendment, or by initiating a new regional planning cycle sooner than the five-year schedule mandated by the OEB.

Appendix A. Methodology and Assumptions for Demand Forecast

The sections that follow describe the IESO's methodology to adjust the forecast for extreme weather, LDC methodologies to forecast demand in their respective service area, and the energy efficiency assumptions used to modify the demand based on expected energy efficiency savings. Table A.3 and Table A.4 show the final non-coincident and coincident extreme demand forecast, respectively, per station used for the Reference Scenario assessments. Table A.5 shows the final coincident extreme demand forecast per station used for the High Growth Scenario assessments. The coincident load forecast includes the estimated reduction due to CDM plus DG with the values shown in Table A.6. Table A.7 also shows the gross demand forecast per station as provided by LDCs.

A.1 Method for Accounting for Weather Impact on Demand

Weather has a large influence on the demand for electricity, so to develop a standardized starting point for the forecast, the historic electricity demand information is weather-normalized. This section details the weather-normalization process used to establish the starting point for regional demand forecasts.

First, the historical loads were adjusted to reflect the median peak weather conditions for each transformer station in the area for the forecast base year (in this case 2018). Median peak refers to what peak demand would be expected if the most likely, or 50th percentile, weather conditions were observed. This means that in any given year there is an estimated 50% chance of exceeding this peak, and a 50% chance of not meeting this peak. The methodological steps are described in Figure A.1.

The 2018 median weather peak on a station and LDC load basis was provided to each LDC. This data was used as a reference starting point from which to develop 20-year demand forecasts, using the LDCs preferred methodology (described in the next sections).

Once the 20-year horizon, median peak demand forecasts were returned to the IESO, the normal weather forecast was adjusted to reflect the impact of extreme weather conditions on electricity demand. The studies used to assess the adequacy and reliability of the electric power system generally require studies to be based on extreme weather demand, or, expected demand under the hottest weather conditions that can be reasonably expected to occur. Peaks that occur during extreme weather (e.g. summer heat waves) are generally when the electricity system infrastructure is most stressed.

Figure A.1 | Method for Determining the Weather-Normalized Peak

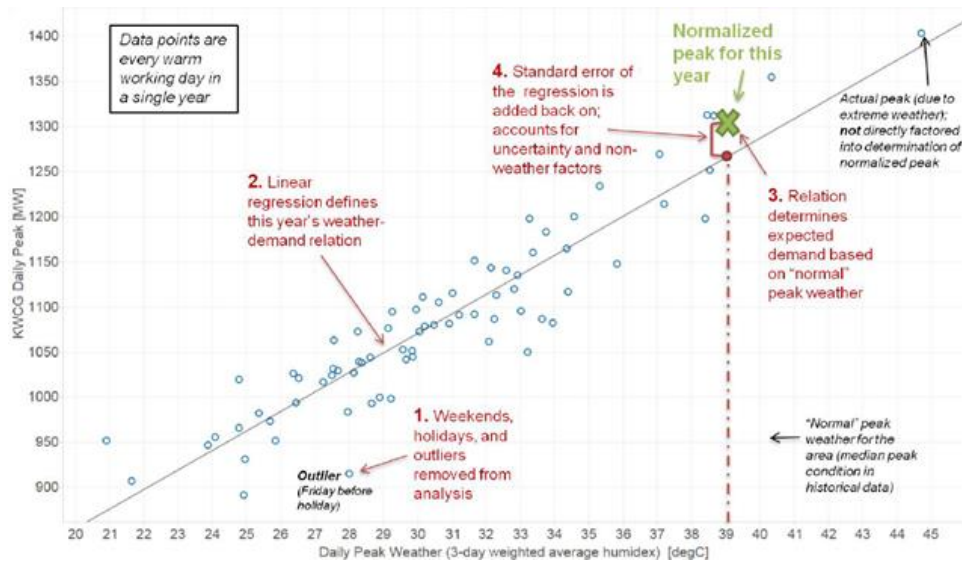

A.2 Hydro One Forecast Methodology

Hydro One Distribution provides service across Ontario, including the to counties and townships within Southern Huron-Perth. Three step-down stations supply the distribution-connected customers in the area from the transmission system as follows:

- 115/27.6 kV Centralia TS supplied by 115 kV circuit L7S
- 115/27.6 kV Grand Bend East DS supplied by 115 kV circuit L7S
- 115/27.6 kV St. Marys TS supplied by 115 kV circuits L7S and D8S

There are about 1.4 million Hydro One Distribution retail customers directly connected to Hydro One’s distribution system, of which Southern Huron-Perth represents about 8.7% of Hydro One’s total electrical load. Hydro One Distribution’s customer base within Southern Huron-Perth is comprised of primarily residential (68%) and commercial loads (25%), with some industrial loads (7%). There are two embedded LDCs connected to Hydro One’s distribution system within Southern Huron-Perth.

A.2.1 Factors that Affect Electricity Demand

In the Southern Huron-Perth sub-region overall, the agricultural sector and population growth are the main factors of electrical demand growth, impacting the organic residential and commercial growth to support the economic development. The growth is expected to continue to occur around the developed areas in the sub-region. Summer peaks are also impacted by seasonal campground and trailer park loads. There is also an industrial manufacturing load, which may expand over the next few years, which has been accounted for in the High Growth Scenario.

A.2.2 Forecast Methodology and Assumptions

The methodology used was a combination of econometric and end-use forecasting models. These models measured growth from a predetermined baseline demand and took into account the effect of CDM. The following tables outline the growth rate and housing start assumptions used as inputs to the model to account for both provincial and local information.

Table A.1 | Growth Rates for Ontario’s GDP (%)

Year	2017	2018	2019	2020	2021	2022	2023	2024	2025	2026
Growth rate	2.8	2.2	1.7	1.7	1.9	2.0	2.0	2.0	2.0	2.0

Table A.2 | Ontario’s Housing Starts (in thousands)

Year	2017	2018	2019	2020	2021	2022	2023	2024	2025	2026
Housing Starts	9.1	78.4	72.1	70.4	71.7	71.1	71.0	68.7	68.9	68.3

A.3 Festival Hydro Forecast Methodology

Festival Hydro owns and operates the electricity distribution system in its licensed service areas of Stratford, Brussels, Dashwood, Hensall, St. Marys, Seaforth and Zurich, providing power to 20,000 people.

The stations of concern for this IRRP are the following:

- 115/27.6 kV Grand Bend East DS supplied by 115 kV circuit L7S
- 115/27.6 kV St. Marys TS supplied by 115 kV circuits L7S and D8S

These stations represent 15-20% of Festival Hydro’s total electrical load. Festival Hydro’s customer base within Southern Huron-Perth is comprised of primarily residential (21%) and industrial loads (56%), along with commercial loads (18%) and mixed commercial/industrial use loads (5%). These loads are supplied through the Hydro One transmission system at primary voltages of 115 kV. Electricity is then distributed through Festival Hydro’s service area by two transformer stations within Southern Huron-Perth.

A.3.1 Factors that Affect Electricity Demand

The main variable affecting electricity demand within Festival Hydro’s service territory within Southern Huron-Perth is related to population growth and economic development, typically attributed to residential service upgrades and new in-fill development. There is little to no residential development or commercial/industrial load growth is known at this time.

A.3.2 Forecast Methodology and Assumptions

Festival Hydro’s load forecast was based on 5-year average plus 0.5% growth each year starting in 2019, following the trend of the last 5 years.

There is also small distribution-connected battery storage facility within Festival Hydro’s Southern Huron-Perth service area. For the purposes of this IRRP forecast, this was not relied on to provide any capacity relief because of uncertainties in their behavior at the time of peak demand as it is a non-contracted behind-the-meter facility.

A.4 Entegrus Powerlines Inc. Forecast Methodology

Entegrus is a corporation, incorporated under the laws of the Province of Ontario to distribute electricity and carry on the business of an electricity distributor within its licensed service area. Entegrus owns, operates and manages the assets associated with the distribution of electrical power to approximately 59,000 customers in 17 Southwestern Ontario communities. Entegrus is owned by the Municipality of Chatham-Kent, the City of St. Thomas, and Corix utilities, and is made up of four divisions, including Entegrus Powerlines Inc.

Entegrus provides safe, sustainable and reliable power to Entegrus customers in Blenheim, Bothwell, Chatham (including a portion of the Township of Raleigh known as the “Bloomfield Business Park”), Dresden, Dutton, Erieau, Merlin, Mount Brydges, Newbury, Parkhill, Ridgetown, St. Thomas, Strathroy, Thamesville, Tilbury, Wallaceburg and Wheatley. For the Southern Huron Perth sub-region, the only area served by Entegrus in this region is the town of Parkhill. Entegrus serves approximately 774 customers within this town. This town represents the furthest North community served by Entegrus. The image below represents the Parkhill Entegrus service boundaries. Entegrus’ customer base within Southern Huron-Perth is comprised of primarily residential (87%) and commercial loads (13%), supplied through the Hydro One transmission system at primary voltages of 115 kV. Electricity is then distributed through Entegrus’ service area by one transformer station within Southern Huron-Perth.

Figure A.2 | Entegrus’ Licensed Utility Service Area within Southern Huron-Perth – Parkhill

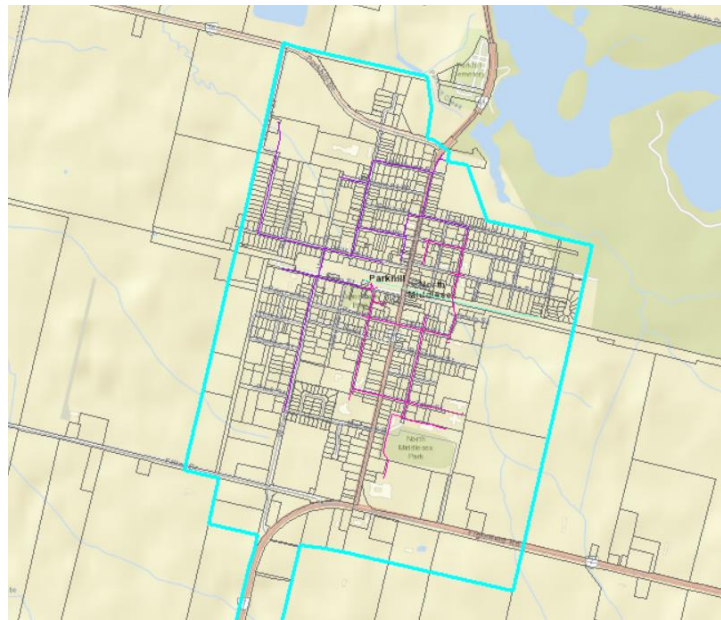

A.4.1 Factors that Affect Electricity Demand

Parkhill has not seen a lot of growth, nor does the town have any pending connection or generation requests at this time. Projected growth is based on organic

Note, the type of forecasts provided varies based on region and amount of information Entegrus knows at the time of the forecast generation. For example, other areas served by Entegrus with

known development, municipal growths plans, and large spot load connections will be incorporated into the forecast. Parkhill historically has been very stable with little growth.

A.4.2 Forecast Methodology and Assumptions

The historical peaks generated in the load forecast template are measured from the Entegrus demarcation wholesale meter and occurred under normal operating conditions. The historical peaks are the metered values for summer and winter. The forecast provided is the net load, i.e., gross peak load minus any existing distributed generation. The town of Parkhill has little generation offsetting the peak. The town is only fed from one supply, so there is no ability for Entegrus to consider load transfers when recording peak data. The town is summer peaking, but the differential between winter and summer month peaks are minor, approximately 300 kW. The town of Parkhill's net load summer peak represents approximately 1% of the entire Entegrus aggregated system peak. The load forecast for Parkhill is primarily based off linear regression (historical net load trend).

A.5 Conservation Assumptions in Demand Forecast

Conservation measures can reduce the electricity demand and their impact can be separated into the two main categories: Building Codes & Equipment Standards, and Conservation Programs. The assumptions used for the Southern Huron-Perth IRRP forecast are consistent with the energy efficiency assumptions in the IESO's 2019 Annual Planning Outlook, which was the latest provincial planning product when this IRRP was developed, the savings for each category were estimated according to the forecast residential, commercial, and industrial gross demand. A top down approach was used to estimate peak demand savings from provincial level to the Southwest transmission zone and then allocated to Southern Huron-Perth sub-region. This appendix describes the process and methodology used to estimate energy efficiency savings for the Southern Huron-Perth sub-region and provides more detail on how the savings for the two categories were developed.

A.5.1 Estimate Savings from Building Codes and Equipment Standards

Ontario building codes and equipment standards set minimum efficiency levels through regulations and are projected to improve and further contribute to demand reduction in the future. To estimate the impact on the region, the associated peak demand savings for codes and standards by sector were estimated for the Southwest zone and compared with the gross peak demand forecast for the zone. From this comparison, annual peak reduction percentages were developed for the purpose of allocating the associated savings to each station in the region.

Consistent with the gross demand forecast, 2018 was used as the base year. New peak demand savings from codes and standards were estimated from 2019 to 2038. The residential annual peak reduction percentages of each year were applied to the forecast residential demand at each station to develop an estimate of peak demand impacts from codes and standards. By 2038, the residential sector in the region is expected to see about 7.1% peak demand savings through standards. The same is done for the commercial sector, which will see about 4.9% peak-demand savings through codes and standards by 2038. The sum of the savings associated with the two sectors are the total peak demand impact from codes and standards. There are no savings from codes and standards considered to be associated with the industrial sector.

A.5.2 Estimate Savings from Conservation Programs

In addition to codes and standards, the delivery of conservation programs reduces electricity demand. The impact of existing and committed conservation programs were analyzed, which include the Conservation First Framework wind-down and the Interim Framework. A top down approach was used to estimate the peak demand reduction due to the delivery of 2019 and 2020 programs, from provincial to Southwest zone to the stations in the region. Persistence of the peak demand savings from energy efficiency programs were considered over the forecast period.

Similar to the estimation of peak demand savings from codes and standards, annual peak demand reduction percentages of program savings were developed by sector. The sectoral percentages were derived by comparing the forecasted peak demand savings with the corresponding gross forecasts in Southwest transmission zone. They were then applied to sectoral gross peak forecast of each station in the region. By 2020, the residential sector in the region is expected to see about 0.6% peak demand savings through programs, while commercial sector and industrial sector will see about 2.3% and 0.7% peak reduction respectively. Those savings will decay over time as the energy efficiency measures come to the end of their effective useful lives.

Note, for all larger industrial customers, this general method is not used to allocate savings to the specific locations. Instead, specific activities undertaken by those facilities are identified based on targeted engagement to include only the savings that are planned.

Since the demand forecast was established in 2019, the subsequent federal and Ontario 2021-2024 programs were not included in the estimated savings. However, when calculating the total achievable potential savings, this is accounted for under the committed savings amount, with costs allocated to the existing program. Accounting for both federal and Ontario programs between 2019-2024, by 2024 the residential sector in the region is expected to see about 0.6% peak demand savings through programs, while commercial sector and industrial sector will see about 6% and 3.2% peak reduction respectively. Similarly, those savings will decay over time as the energy efficiency measures come to the end of their effective useful lives.

A.5.3 Total Conservation Savings and Impact on the Planning Forecast

As described in the above sections, peak demand savings were estimated by sector for each forecast category, and totalled for each station in the region. The analyses were conducted under normal weather conditions and can be adjusted to reflect extreme weather conditions. The resulting forecast savings were applied to gross demand to determine net peak demand for further planning analyses.

Table A.3 | Reference Summer Non-Coincident Extreme Peak Demand Forecast (MW) per Station in Southern Huron-Perth Sub-Region

Station	2021	2022	2023	2024	2025	2026	2027	2028	2029	2030	2031	2032	2033	2034	2035	2036	2037	2038
Centralia TS	37	40	41	41	41	41	42	42	42	42	43	43	44	44	44	45	46	46
Grand Bend East DS	22	22	22	22	22	22	22	22	22	22	23	23	23	23	24	24	24	24
St. Marys TS	28	28	28	28	28	29	29	29	29	30	30	30	31	31	31	31	32	32
CTS #4	15	15	15	15	15	15	15	15	15	15	15	15	15	15	15	15	15	15
CTS #1	3	3	3	3	3	3	3	3	3	3	3	3	3	3	3	3	3	3
CTS #3	5	5	5	5	5	5	5	5	5	5	5	5	5	5	5	5	5	5
CTS #2	7	7	7	7	7	7	7	7	7	7	7	7	7	7	7	7	7	7
Total	117	120	121	121	121	122	122	123	124	124	125	126	127	128	129	130	132	133

Table A.4 | Reference Summer Coincident Extreme Peak Demand Forecast (MW) per Station in Southern Huron-Perth Sub-Region

Station	2021	2022	2023	2024	2025	2026	2027	2028	2029	2030	2031	2032	2033	2034	2035	2036	2037	2038
Centralia TS	34	36	37	37	37	37	37	38	38	38	38	39	39	40	40	40	41	42
Grand Bend East DS	16	16	16	16	16	17	17	17	17	17	17	17	17	17	18	18	18	18
St. Marys TS	25	26	26	26	26	26	27	27	27	27	27	28	28	28	29	29	29	30
CTS #4	13	13	13	13	13	13	13	13	13	13	13	13	13	13	13	13	13	13
CTS #1	2	2	2	2	2	2	2	2	2	2	2	2	2	2	2	2	2	2
CTS #3	0	0	0	0	0	0	0	0	0	0	0	0	0	0	0	0	0	0
CTS #2	6	6	6	6	6	6	6	6	6	6	6	6	6	6	6	6	6	6
Total	97	100	100	101	101	102	102	103	103	104	104	105	106	107	108	109	110	111

Table A.5 | High Growth Summer Coincident Extreme Peak Demand Forecast (MW) per Station in Southern Huron-Perth Sub-Region

Station	2021	2022	2023	2024	2025	2026	2027	2028	2029	2030	2031	2032	2033	2034	2035	2036	2037	2038
Centralia TS	34	36	37	37	40	40	40	40	41	44	44	45	45	46	49	50	51	51
Grand Bend East DS	16	16	16	16	16	16	17	17	17	17	17	17	17	17	18	18	18	18
St. Marys TS	25	26	26	26	31	31	31	31	32	37	37	38	38	38	44	44	44	45
CTS #4	13	13	13	13	13	13	13	13	13	13	13	13	13	13	13	13	13	13
CTS #1	2	2	2	2	2	2	2	2	2	2	2	2	2	2	2	2	2	2
CTS #3	0	0	0	0	0	0	0	0	0	0	0	0	0	0	0	0	0	0
CTS #2	6	6	6	6	6	6	6	6	6	6	6	6	6	6	6	6	6	6
Total	97	100	100	100	109	109	110	110	111	119	120	121	122	123	132	133	135	135

Table A.6 | CDM and DG Contribution (MW) Considered in Reference Coincident Extreme Peak Demand Forecast

Station	2021	2022	2023	2024	2025	2026	2027	2028	2029	2030	2031	2032	2033	2034	2035	2036	2037	2038
Centralia TS	2.8	3.0	3.2	3.4	3.5	3.7	3.9	4.0	4.2	4.3	4.1	3.8	3.9	3.9	3.9	3.7	3.1	3.1
Grand Bend East DS	1.3	1.4	1.5	1.6	1.7	1.8	1.9	1.9	2.0	2.1	2.0	2.1	2.0	2.0	1.5	1.5	1.5	1.5
St. Marys TS	0.9	0.9	1.0	1.1	1.1	1.2	1.3	1.3	1.3	1.4	1.3	1.3	1.2	1.2	1.3	1.3	1.2	1.1
CTS #4	0	0	0	0	0	0	0	0	0	0	0	0	0	0	0	0	0	0
CTS #1	0	0	0	0	0	0	0	0	0	0	0	0	0	0	0	0	0	0
CTS #3	0	0	0	0	0	0	0	0	0	0	0	0	0	0	0	0	0	0
CTS #2	0	0	0	0	0	0	0	0	0	0	0	0	0	0	0	0	0	0
Total	5.0	5.3	5.7	6.0	6.4	6.6	7.0	7.2	7.5	7.7	7.4	7.1	7.1	7.1	6.6	6.4	5.8	5.7

Table A.7 | Reference Summer LDC Coincident Gross Peak Demand Forecast (MW) per Station in Southern Huron-Perth Sub-Region

Station	2021	2022	2023	2024	2025	2026	2027	2028	2029	2030	2031	2032	2033	2034	2035	2036	2037	2038
Centralia TS	37	40	41	41	42	42	42	43	43	43	44	44	44	45	45	45	46	46
Grand Bend East DS	21	21	21	21	22	22	22	22	22	22	22	23	23	23	23	23	23	23
St. Marys TS	26	27	27	27	28	28	28	28	29	29	29	29	30	30	30	30	31	31
CTS #4	15	15	15	15	15	15	15	15	15	15	15	15	15	15	15	15	15	15
CTS #1	3	3	3	3	3	3	3	3	3	3	3	3	3	3	3	3	3	3
CTS #3	5	5	5	5	5	5	5	5	5	5	5	5	5	5	5	5	5	5
CTS #2	7	7	7	7	7	7	7	7	7	7	7	7	7	7	7	7	7	7
Total	115	118	119	120	121	121	122	123	124	124	125	126	127	127	128	129	129	130

Appendix B. Solution Options to Supply Capacity Need in the High Growth Scenario

Table B.1 | Comparison of Solution Options for High Growth Scenario Needs

Option	Description	Load Supply Capability (MW)	Total Cost	Cost per Additional MW of Supplied Load
1	Transfer load from Centralia TS to Seaforth TS	4.4*	\$6-12M	\$136-273k
2	Conservation and Demand Management	16.1**	\$26M***	\$1.62M***-
3	Upgrade limiting section of L7S 115 kV circuit	50	\$10-15M	\$200-300k

*This is will will require a new feeder position at Seaforth TS, included in the costs.

**Maximum uncommitted CDM potential, net of the 0.9 MW of comitted CDM from forecast and planned provincial and federal CDM programs. This potential would be achieved through new initiatives. Costs are based on historic CDM program costs.

*** Cost for these system cost-effective resources will be recovered through a provincial program.

Appendix C. Development of the Plan

C.1 The Regional Planning Process

In Ontario, meeting the electricity needs of customers at a regional level is achieved through regional planning. This comprehensive process starts with an assessment of the interrelated needs of a region—defined by common electricity supply infrastructure—over the near, medium, and long term and results in the development of a plan to ensure cost-effective, reliable electricity supply. Regional plans consider the existing electricity infrastructure in an area, forecast growth and customer reliability, evaluate options for addressing needs, and recommend actions.

Regional planning has been conducted on an as-needed basis in Ontario for many years. Most recently, planning activities to address regional electricity needs were the responsibility of the former Ontario Power Authority (OPA), now the Independent Electricity System Operator (IESO), which conducted joint regional planning studies with distributors, transmitters, the IESO and other stakeholders in regions where a need for coordinated regional planning had been identified.

In the fall of 2012, the OEB convened a Planning Process Working Group (PPWG) to develop a more structured, transparent, and systematic regional planning process. This group was composed of electricity agencies, utilities, and other stakeholders. In May 2013, the PPWG released its report to the OEB (PPWG Report), setting out the new regional planning process. Twenty-one electricity planning regions were identified in the PPWG Report, and a phased schedule for completion of regional plans was outlined. The OEB endorsed the PPWG Report and formalized the process timelines through changes to the Transmission System Code and Distribution System Code in August 2013, and to the former OPA's licence in October 2013. The licence changes required it to lead two out of four phases of regional planning. After the merger of the IESO and the OPA on January 1, 2015, the regional planning roles identified in the OPA's licence became the responsibility of the IESO.

The regional planning process begins with a needs assessment process performed by the transmitter, which determines whether there are needs requiring regional coordination. If regional planning is required, the IESO conducts a scoping assessment to determine what type of planning is required for a region. A scoping assessment explores the need for a comprehensive IRRP, which considers conservation, generation, transmission, and distribution solutions, or whether a more limited "wires" solution is the preferable option, in which case a transmission- and distribution-focused RIP can be undertaken instead. There may also be regions where infrastructure investments do not require regional coordination and can be planned directly by the distributor and transmitter outside of the regional planning process. At the conclusion of the scoping assessment, the IESO produces a report that includes the results of the needs assessment process and a preliminary terms of reference. If an IRRP is the identified outcome, the IESO is required to complete the IRRP within 18 months. If a RIP is the identified outcome, the transmitter takes the lead and has six months to complete it. Both RIPs and IRRPs are to be updated at least every five years. The draft Scoping Assessment Outcome Report is posted to the IESO's website for a two-week public comment period prior to finalization.

The final Needs Assessment Reports, Scoping Assessment Outcome Reports, IRRPs and RIPs are posted on the IESO's and the relevant transmitter's websites, and may be referenced and submitted to the OEB as supporting evidence in rate or "Leave to Construct" applications for specific infrastructure investments. These documents are also useful for municipalities, First Nation communities and Métis community councils for planning, and for conservation and energy management purposes. They are also a useful source of information for individual large customers that may be involved in the region, and for other parties seeking an understanding of local electricity growth, CDM and infrastructure requirements. Regional planning is not the only type of electricity planning undertaken in Ontario. As shown in Figure C.1, three levels of electricity system planning are carried out in Ontario:

- Bulk system planning;
- Regional system planning; and
- Distribution system planning.

Planning at the bulk system level typically considers the 230 kV and 500 kV network and examines province-wide system issues. In addition to considering major transmission facilities or "wires", bulk system planning assesses the resources needed to adequately supply the province. This type of planning is typically carried out by the IESO pursuant to government policy. Distribution planning, which is carried out by LDCs, considers specific investments in an LDC's territory at distribution-level voltages.

Regional planning can overlap with bulk system planning and with the distribution planning of LDCs. For example, overlaps can occur at interface points where there may be regional resource options to address a bulk system issue or when a distribution solution addresses the needs of the broader local area or region. As a result, it is important for regional planning to be coordinated with both bulk and distribution system planning, as it is the link between all levels of planning.

By recognizing the linkages with bulk and distribution system planning, and coordinating the multiple needs identified within a region over the long term, the regional planning process provides a comprehensive assessment of a region's electricity needs. Regional planning aligns near- and long-term solutions and puts specific investments and recommendations coming out of the plan into perspective. Furthermore, in avoiding piecemeal planning and asset duplication, regional planning optimizes ratepayer interests, allowing them to be represented along with the interests of LDC ratepayers, and individual large customers. IRRPs evaluate the multiple options that are available to meet the needs, including conservation, generation, and "wires" solutions. Regional plans also provide greater transparency through engagement in the planning process, and by making plans available to the public.

Figure C.1 | Levels of Electricity System Planning

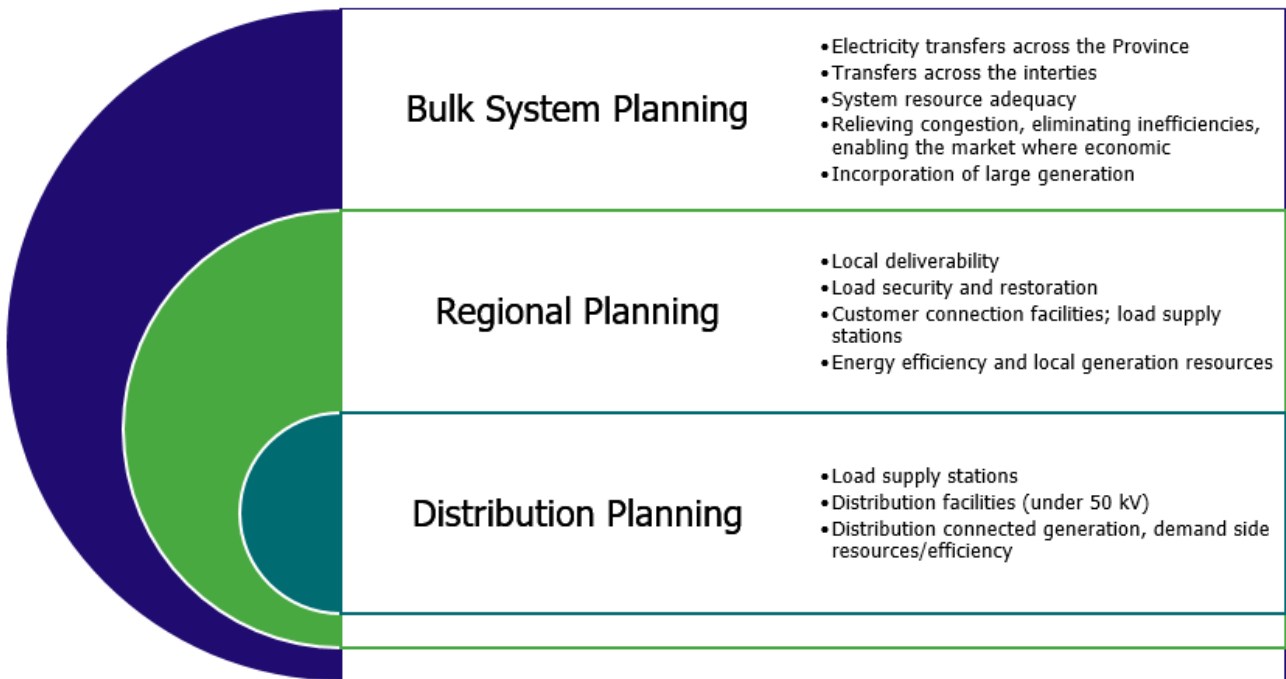

C.2 IESO’s Approach to Regional Planning

IRRP assess electricity system needs for a region over a 20-year period, enabling near-term actions to be developed in the context of a longer-term view of trends. This enables coordination and consistency with the long-term plan, rather than simply reacting to immediate needs.

The IRRP describes the Working Group’s recommendations for mitigating reliability and cost risks related to end-of-life asset replacement and demand forecast uncertainty associated with large load customers or due to any changes in the existing provincial conservation targets. The IRRP helps ensure that recommendations to address near-term needs are implemented, while maintaining the flexibility to accommodate changing long-term conditions.

In developing an IRRP, the IESO and the study team follow a process, with a clearly defined series of steps (see Figure C.2). These includes developing electricity demand forecasts; conducting technical studies to determine electricity needs and the timing of these needs; considering potential options; and creating a plan with recommended actions for the near and long term. Throughout this process, engagement is carried out with stakeholders and Indigenous communities who may have an interest in the area.

The IRRP report documents the inputs, findings and recommendations developed through this process, and outlines recommended actions for the various entities responsible for plan implementation. Where “wires” solutions are included in the plan recommendations, the completion of the IRRP triggers the initiation of the transmitter’s RIP process to develop those options. Other recommendations in the IRRP may include: development of conservation, local generation, community engagement, or information gathering to support future iterations of the regional planning process in the region or sub-region.

Figure C.2 | Steps in the IRRP Process

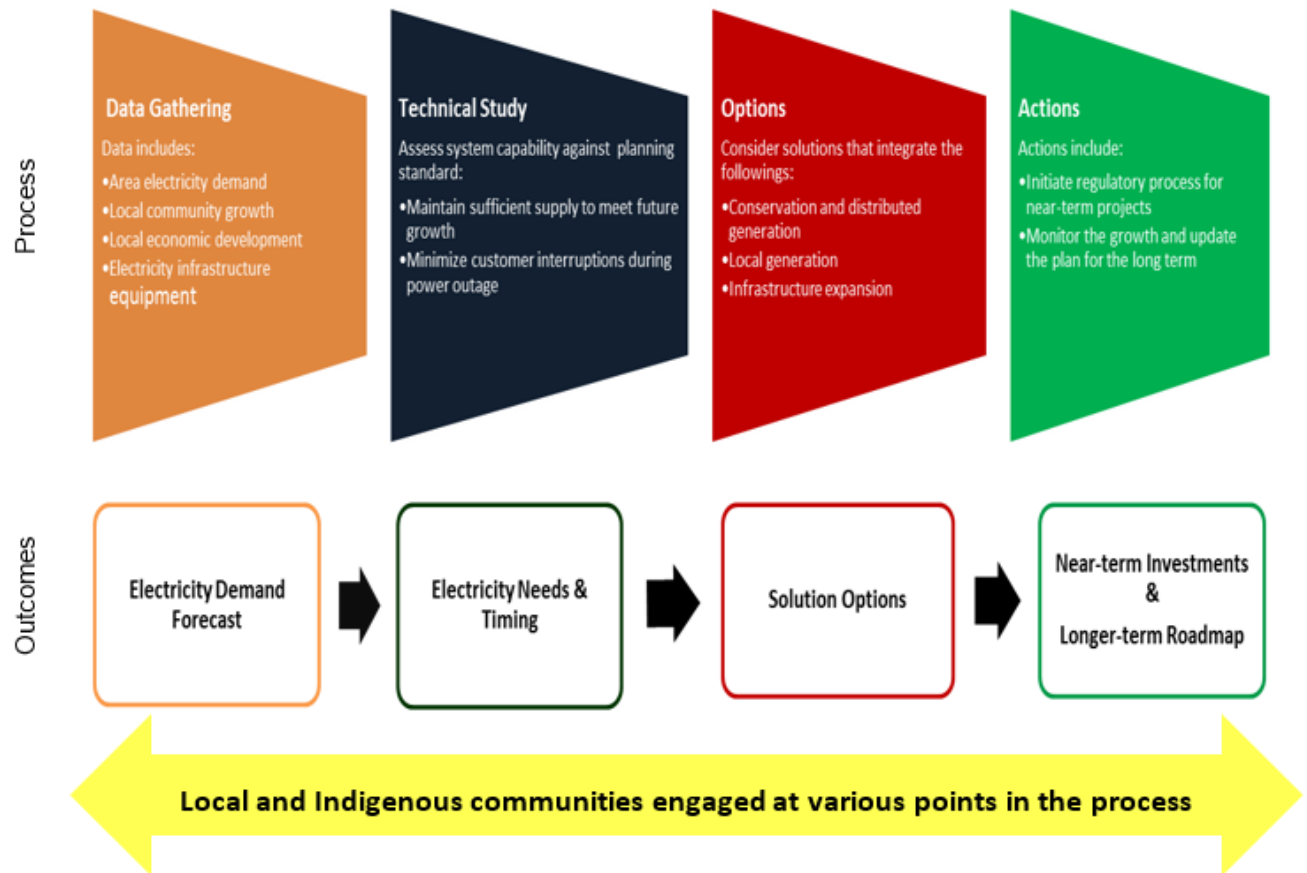

**Independent Electricity
System Operator**

1600-120 Adelaide Street West
Toronto, Ontario M5H 1T1

Phone: 905.403.6900

Toll-free: 1.888.448.7777

E-mail: customer.relations@ieso.ca

ieso.ca

 [@IESO Tweets](https://twitter.com/IESO)

 facebook.com/OntarioIESO

 linkedin.com/company/IESO