

# WINDSOR-ESSEX REGION SCOPING ASSESSMENT OUTCOME REPORT

MARCH 2, 2018



**Table of Contents**

1. Introduction ..... 3

2. Team..... 4

3. Categories of Needs, Analysis and Results ..... 5

    3.1 Overview of the Region ..... 5

    3.2 Background..... 6

    3.3 Needs Identified..... 7

    3.4 Analysis of Needs and Planning Approach..... 10

4. Conclusion ..... 12

List of Acronyms ..... 13

Appendix A: The Windsor-Essex IRRP Terms of Reference ..... 14

## Scoping Assessment Outcome Report Summary

<b>Region:</b>	Windsor-Essex		
<b>Start Date</b>	December 6, 2017	<b>End Date</b>	March 2, 2018

### 1. Introduction

This Scoping Assessment Outcome Report is part of the Ontario Energy Board's "OEB" or "Board" Regional Planning process. The scoping assessment process was led by the IESO in collaboration with the Regional Participants to determine the regional planning approach for the Windsor-Essex region for the needs identified by Hydro One Networks Inc. "Hydro One" in the Needs Assessment Report<sup>1</sup> published in October 2017.

The first cycle of the regional planning process in the Windsor-Essex region was completed in 2015. Planning activities for the Windsor-Essex Region were already underway before the new regional planning process was introduced in 2013. The Needs Assessment ("NA") and Scoping Assessment ("SA") phases were deemed to be complete and the Windsor-Essex Region was identified as a "transitional" region. The Integrated Regional Resource Plan<sup>2</sup> ("IRRP") was published in April 2015 followed by the publication of the Windsor-Essex Regional Infrastructure Plan<sup>1</sup> ("RIP") in December 2015.

In accordance with the regional planning process, a regional planning cycle should be triggered every five years, or less if there are emerging needs. The NA completed in October 2017 was triggered by significant load growth and a new load forecast in the Kingsville-Leamington area. The final report concluded that some needs in the region may require regional coordination and more comprehensive planning, and should be reviewed further under the IESO-led scoping assessment process which is the second stage in the Board's regional planning process.

The Independent Electricity System Operator ("IESO"), in collaboration with the Regional Participants, further reviewed the needs identified along with information collected during the Needs Assessment, information on potential wires and non-wires alternatives, and the overall regional area impact to assess and determine the best planning approach for the whole or parts of the region. The available planning options considered in the Scoping Assessment include: an Integrated Regional Resource Plan, a Regional Infrastructure Plan (wires only plan), or a Local Plan.

---

<sup>1</sup> The Regional Infrastructure Plan from the previous planning cycle and the Needs Assessment report for the Windsor-Essex Region can be found at:

<https://www.hydroone.com/about/corporate-information/regional-plans/windsor-essex>

<sup>2</sup> The Integrated Regional Resource Plan for the Windsor-Essex Region can be found at:

<http://www.ieso.ca/get-involved/regional-planning/southwest-ontario/windsor-essex>

This Scoping Assessment report:

- defines the region (or sub-regions) for needs requiring more comprehensive planning as identified in the Needs Assessment report;
- determines the appropriate regional planning approach and scope for the region where a need for regional coordination or more comprehensive planning is identified;
- establishes a terms of reference when the IRRP is the recommended approach; and
- establishes the IRRP working group.

## 2. Team

The Scoping Assessment was carried out with the following Regional Participants:

- Independent Electricity System Operator
- Enwin Utilities Ltd.
- Essex Powerlines Corporation
- E.L.K Energy Inc.
- Entegrus Inc.
- Hydro One Networks Inc. (Distribution)
- Hydro One Networks Inc. (Transmission)

### 3. Categories of Needs, Analysis and Results

#### 3.1 Overview of the Region

The Region is comprised of the City of Windsor, Town of Amherstburg, Town of Essex, Town of Kingsville, Town of Lakeshore, Town of LaSalle, Municipality of Leamington, Town of Tecumseh, and the western portion of the Municipality of Chatham-Kent and the Township of Pelee Island. The Windsor-Essex region also includes the Caldwell First Nation.

This Region, shown in Figure 1 below is comprised of and is served by five Local Distribution Companies (LDCs): EnWin Utilities Ltd., EnWin Essex Powerlines Corporation, E.L.K. Energy Inc., Entegrus Inc., and Hydro One. EnWin and Hydro One are directly connected to the transmission system, while the three other LDCs have low voltage connections to Hydro One distribution feeders.

Figure 1: Electricity Infrastructure in the Windsor-Essex Region

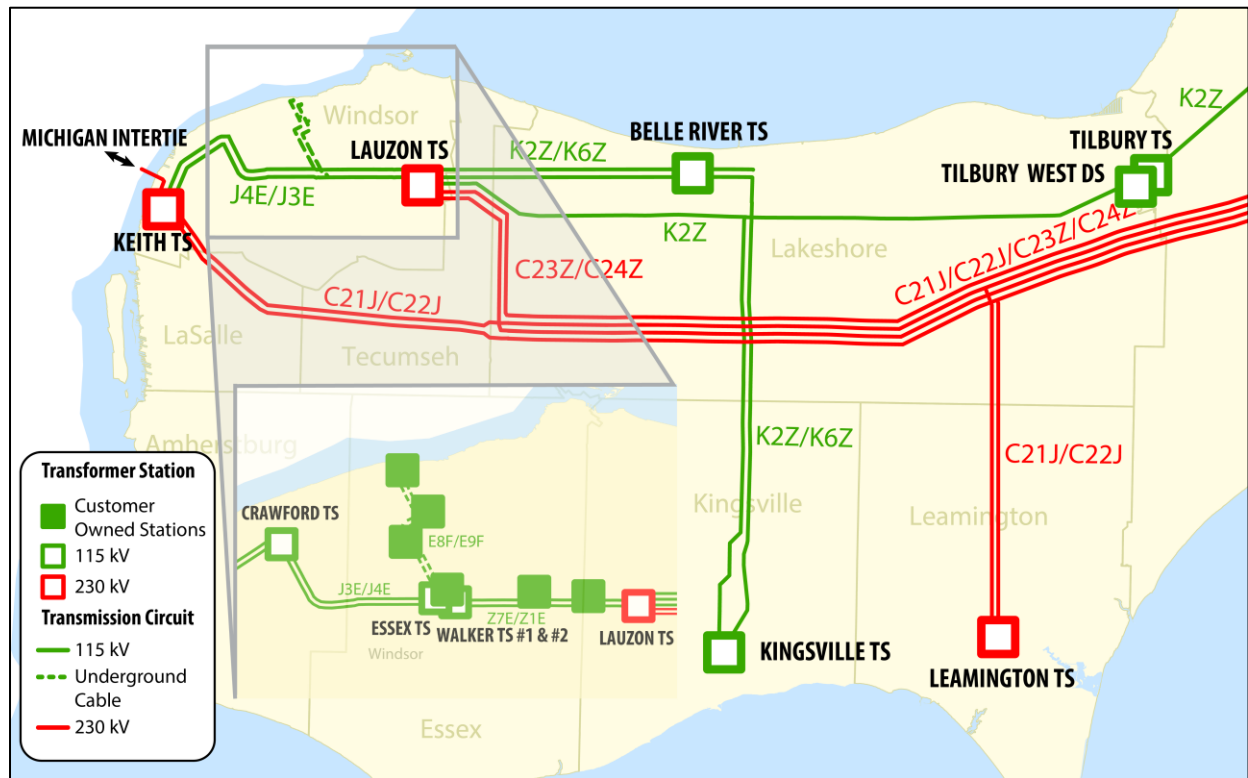

The Region is supplied from a combination of local generation and from connection to the Ontario grid via a network of 230 kV and 115 kV transmission lines and stations shown in Figure 2 below. Electricity distribution and conservation initiatives are carried out by the five LDCs serving the Region.

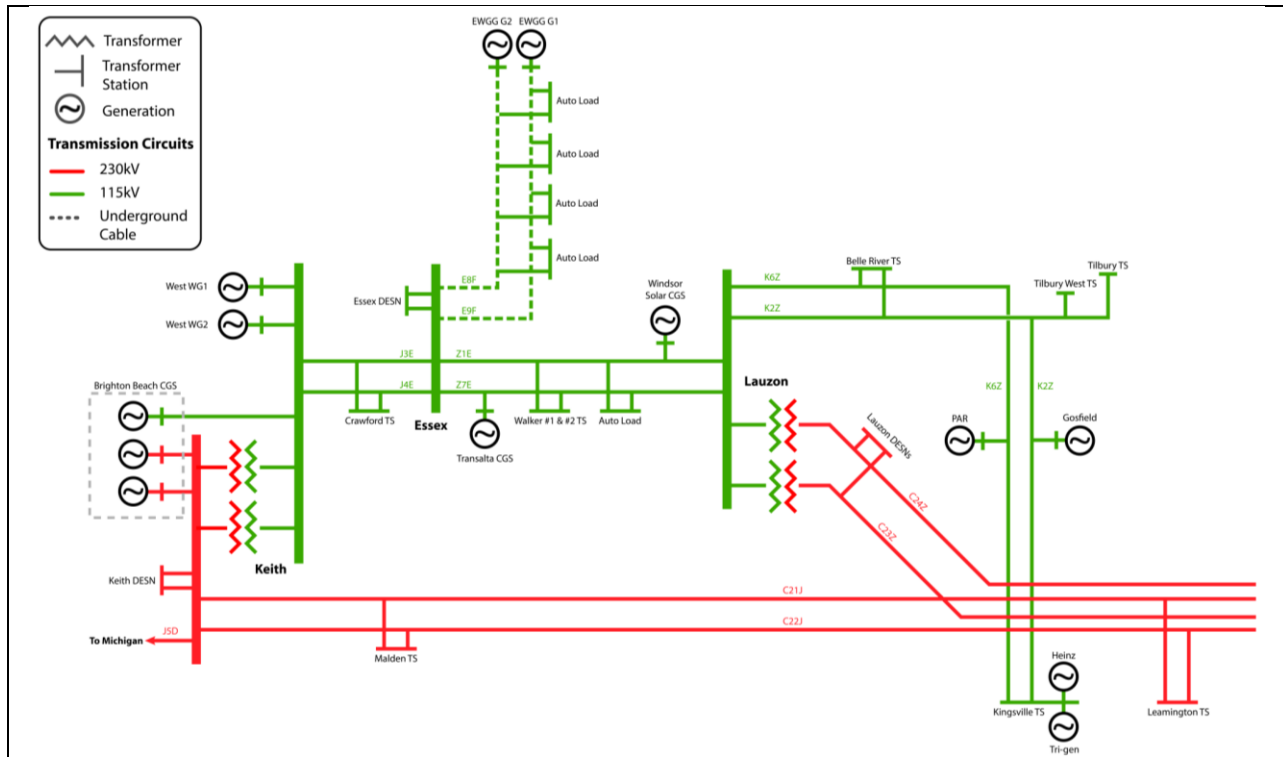

**Figure 2: Single Line Diagram of Windsor-Essex Region**

The urban portion of the Region in and around Windsor has a long history of advanced manufacturing, especially in the automotive sector. In light of this the transmitter and distributors have made historical investments in electricity infrastructure to enable a very high standard of reliability, which is of strategic importance to the regional and provincial economies. Entertainment tourism is particularly strong in the downtown core, the most significant individual component of which is a provincially owned resort casino.

The rural portion of the Region in Essex County supports a combination of manufacturing and agri-business. Essex County contains the largest concentration of greenhouse vegetable production in North America. This sector is expected to experience major growth in the future with much of the activity taking place in the Kingsville and Leamington areas, increasing electricity supply requirements. The County is also home to several large food processing operations, and a growing winery sector.

### 3.2 Background

This is the second cycle of regional planning for the Windsor-Essex Region. In the previous cycle, regional planning was underway in the Windsor-Essex Region prior to the OEB's formalization of the regional planning process. The first phase of regional planning began with the regional plan developed by the former Ontario Power Authority ("OPA") as part of the 2007 Integrated Power System Plan ("IPSP") which identified a need for conservation as well as transmission reinforcement in the Region.

In 2010, a working group consisting of members from the former OPA, the transmitter, the five LDCs, and the IESO was formed. A study carried out by the former OPA and presented to the working group in 2011 recommended that development activities associated with the proposed Leamington TS temporarily be put on hold as a result of reduced regional electricity demand. In 2013, the former OPA revisited this study with an updated load forecast and the Supply to Essex County Transmission Reinforcement (“SECTR”) project was recommended to address near-term needs in the Kingsville-Leamington area.

In January 2014, Hydro One submitted a Leave to Construct application for this project with the OEB. As a continuation of this planning work for the Region the former-OPA completed the Windsor-Essex IRRP in April 2015. The RIP was published by Hydro One shortly after in December 2015. The RIP indicated that load at Kingsville TS was expected to be maintained under 50 MW and that load beyond this limit would be transferred to the new Leamington TS, expected to be in service by 2018. However, Hydro One Distribution indicated that they would engage in further assessment of the planned Kingsville TS reconfiguration if additional requests for connections were received.

The Needs Assessment was triggered in June 2017 due to significant forecast load growth in the Kingsville-Leamington area as a result of greenhouse sector expansion, above and beyond what had been forecast in the 2015 IRRP. Hydro One completed the Needs Assessment for the Windsor-Essex region on October 24th, 2017. Based on the forecast included in the Needs Assessment, the area supplied by Kingsville TS will become winter peaking by 2019. It is also forecast to exceed the capability of the downsizing plan originally proposed in the 2015 IRRP.

The needs identified in Hydro One’s Needs Assessment form the basis of the analysis for the Scoping Assessment and are discussed in further detail in Section 3.3.

### **3.3 Needs Identified**

Hydro One’s Needs Assessment identified a number of needs in the Windsor-Essex region based on load forecasts, forecasted impacts of planned conservation and demand management (“CDM”) programs/expected distributed generation (“DG”) capacity based on existing contracts, system reliability and operational issues in the region, along with major high voltage equipment identified to be at the end of their useful life and requiring replacement or refurbishment. The needs have been outlined below and include: station capacity needs, reliability/restoration needs, and end-of-life needs.

#### **Station Capacity Needs**

The Needs Assessment identified both potential near-term and mid- to long-term capacity needs throughout the planning period at the stations shown in Table 1.

**Table 1: Station Capacity Needs**

Station	Demand	Timing	Note
Kingsville TS	Winter	TBD	Peak load at Kingsville TS is forecast to reach 100 MW in the winter within the next 5 years. This would have exceeded the winter LTR if the station had been downsized to 2x42 MVA units as proposed in the 2015 plan. With Hydro One's current plan to install 2x83 MVA units there is no capacity need in the next 10 years based on transformer capacity, however upstream limitations need to be studied to confirm the station's load meeting capability.
Belle River TS	Summer	Long term <sup>[1]</sup>	Based on summer forecasts, Lauzon TS T5/T6 is expected to exceed station capacity from 2017 to 2023 and Belle River TS is expected to exceed its capacity in 2026. The timing and magnitude of these needs depends heavily on power factor assumptions and the conservation forecast.
Lauzon TS	Summer	Near term <sup>[1]</sup>	
Leamington TS	Winter	Near term	Leamington TS is forecast to exceed its winter LTR by 2021. The IESO has had further conversations with Hydro One Distribution since the completion of the Needs Assessment which indicate the potential load growth may exceed what was known at the time; potentially advancing the need date to as early as 2020 (approximately 80 MW of additional forecast load growth since the Needs Assessment was completed).

[1] Hydro One's Needs Assessment determined that when accounting for improved power factor assumptions, due to the capacitor banks installed at these stations, the need could be deferred beyond 10-year study period.

### Reliability/Restoration/Security Needs

The Needs Assessment identified potential restoration needs for the loss of C23Z/C24Z or C21J/C22J or K2Z/K6Z or Z1E/Z7E. Due to expiring generation contracts in the next 10-15 years, load requiring restoration could increase, impacting the timing and magnitude of these restoration needs.

### Bulk System Needs

In the Needs Assessment, the IESO identified issues related to overvoltage or thermal overload for select breaker failure and multiple element contingencies. These issues are dependent on bulk system conditions such as high import/exports.



## End-of-Life Needs

Hydro One identified the equipment shown in Table 2 to be reaching end-of-life within the study period.

**Table 2: Equipment Reaching End-of-life in the Next 10 Years**

Equipment	Need Date
Crawford TS: T3 Transformer	2017 - Completed
Malden TS: Low Voltage Breakers	2018
Kingsville TS: T1/T2/T3/T4 Transformers	2019
Tilbury TS	2020
Keith TS: Autotransformers	2023
Lauzon TS: T1/T2 Autotransformers, T6 & T7 Step-Down Transformers	2025

Plans are already underway for the majority of these investments, as outlined in the following section. These plans reflect the outcomes of the last cycle of regional planning process or planning that occurred between Hydro One and the applicable LDCs.

## Projects and Plans Underway

The RIP published in December 2015 identified the wires work required to meet existing system needs. The Needs Assessment also identified plans developed by Hydro One and the LDCs in the subsequent period between the RIP and Needs Assessment publication. These projects, outlined in Table 3, provide a basis for future assessments of the region and should be accounted for in planning.

**Table 3: Projects Currently Underway**

Need	Plan	I/S Date
Kingsville TS End-of-Life / Capacity Need	Hydro One and Hydro One Distribution have agreed to install larger units (2x83 MVA).	2019
Crawford TS End-of-Life	Replacement of T3 with the similar unit (83 MVA), removal of grounding transformers units GT3 and GT4, grounding the LV neutrals through Neutral Grounding Reactors and upgrade of associated protection and control systems.	2017 - Completed
Keith TS End-of-Life	Replace end-of-life 230 kV/115 kV autotransformers, upgrading from 125 MVA to 250 MVA units.	2023
	Decommission the end-of-life T1 (115 kV/27.6 kV) transformer.	TBD

Need	Plan	I/S Date
Relocation for Gordie Howe International Bridge Project	Reconfiguration of 230 kV and 115 kV circuits and 27.6 kV feeders at Keith TS to allow for the construction of the Gordie Howe Bridge	2018
Tilbury TS End-of-Life	Decommission of Tilbury TS and transfer of serviced load to a different supply point.	2020
Kingsville-Leamington Capacity Need / 115kV System Restoration Need	SECTR project as outlined in the RIP. Project includes Leamington TS, 13 km 2-circuit 230 kV line and distribution work for Leamington TS.	2018

### 3.4 Analysis of Needs and Planning Approach

An Integrated Regional Resource Plan is recommended for the Windsor-Essex Region due to:

- the potential for non-wires solutions to address the identified capacity and restoration needs,
- the opportunities to maximize use of end-of-life assets,
- the potential reliability impact of large local generation reaching contract expiry in the mid-term and not being re-contracted due to the IESO's Market Renewal project, and
- the need to ensure that future planning is consistent with the decisions made in the first cycle of regional planning.

In addition to the needs requiring regional planning, there are some needs which will be addressed either by the IESO through its bulk planning process or through local planning between the transmitter and the impacted LDC(s).

#### Windsor-Essex Integrated Regional Resource Plan

The IRRP for Windsor Essex Region will focus on ensuring the region continues to have sufficient supply capability, meeting reliability standards, and analyzing assets reaching end-of-life to take advantage of opportunities they may present.

The IRRP will confirm transformer station capacity needs and carry out an assessment of options for confirmed needs, including additional conservation or other non-wires alternatives. The capacity need in the Kingsville and Leamington areas is predicted to continue to grow quickly as more greenhouse operations materialize. The working group recognizes that due to the urgency of the need, as well as the lead time required for potential wires solutions, a hand-

off letter to Hydro One may be required early on in the regional planning process to recommend that Hydro One Transmission proceed with work to provide additional transformation supply to the Leamington area.

The potential for non-wires solutions, such as demand response and distributed energy resources, will still be explored in parallel in order to identify options now to manage continued growth in the Kingsville and Leamington areas over the long term. The IRRP will also identify if any additional 230kV/115kV reinforcements are necessary to accommodate load growth in the area.

The IRRP will further assess the impact of existing conservation programs at Lauzon TS and Belle River TS and confirm the impact on the identified capacity need and timing.

The IRRP will evaluate the impact of the updated demand forecast on restoration needs and collect information on reliability issues and load transfer capabilities. These needs may affect multiple LDCs, and all LDCs may play a role in meeting them. The IRRP will also study the potential impacts of generation in the region going off contract due to the ongoing Market Renewal processes. Non-wires options such as demand response and distributed generation will be considered alongside transmission reinforcement or enhanced load transfer capability.

Facilities reaching end-of-life provide an opportunity to re-examine their current use and configuration in the context of the latest load forecast and generation data to ensure that any new assets installed in their place will continue to appropriately service both the impacted LDCs/ and their customers/ over the new assets' lifetime.

Plans to replace end-of-life facilities at Crawford TS, Kingsville TS, and Keith TS, identified previously in the RIP, are continuing. However, any scope changes/new information should continue to be shared as it becomes available. The IRRP will confirm the new load meeting capabilities of Kingsville TS using the updated demand forecast and Hydro One's latest refurbishment plan, and assess upstream limitations, particularly under winter conditions.

Options to re-configure or up-size end-of-life facilities at Lauzon TS will also be studied in the IRRP due to the potential to address system restoration or supply capacity needs.

The IRRP will also examine the current supply to Tilbury West HVDS to determine if additional reinforcements are required to adequately supply Entegrus load once the decommissioning of Tilbury TS is complete.

### **Bulk System Planning**

In the Needs Assessment, the IESO identified issues related to overvoltage or thermal overload for select breaker failure and multiple element contingencies; these issues are linked to bulk system conditions such as high import/exports. The IESO will conduct a bulk study which may involve updating the Windsor Area remedial action scheme "RAS" Results of the study will

form an input to the IRRP, particularly in options development.

### **Local Planning**

The end-of-life need at Malden TS to replace low voltage breakers does not require further regional planning. A local planning process is recommended to address this need, as it requires a limited investment in a wires solution and does not require further regional stakeholder engagement.

## **4. Conclusion**

The Scoping Assessment concludes that:

- Based on the needs identified in the Needs Assessment, an IRRP is recommended for the Windsor-Essex region. The IRRP scope will include the following:
  - capacity needs in the Kingsville and Leamington areas,
  - confirmation of the load meeting capabilities of Kingsville TS after reconfiguration,
  - capacity needs at Lauzon and Belle River TS,
  - system restoration needs following loss of the C23Z/C24Z or C21J/C22J or K2Z/K6Z or Z1E/Z7E double circuit lines, and
  - Lauzon TS re-configuration or upsizing.
- The work to implement recommendations from the previous IRRP and RIP should continue.
- The IESO will conduct a separate bulk planning process in parallel with IRRP. The results will be incorporated into the regional planning processes as they become available.
- A Local Planning process is recommended for end-of-life needs at Malden TS.

The draft Terms of Reference for the Windsor-Essex IRRP is attached in Appendix A.

## List of Acronyms

CDM	Conservation and Demand Management
DG	Distributed Generation
IESO	Independent Electricity System Operator
IPSP	Integrated Power System Plan
IRRP	Integrated Regional Resource Plan
kV	Kilovolt
LDC	Local Distribution Company
MW	Megawatt
NA	Needs Assessment
NERC	North American Electric Reliability Corporation
NPCC	Northeast Power Coordinating Council
OEB	Ontario Energy Board
OPA	Ontario Power Authority
ORTAC	Ontario Resource and Transmission Assessment Criteria
RAS	Remedial Action Scheme
RIP	Regional Infrastructure Plan
RPP	Regional Planning Process
SA	Scoping Assessment
SECTR	Supply to Essex County Transmission Reinforcement
TS	Transformer Station

# Appendix A0Draft Terms of Reference 1

---

## The Windsor-Essex IRRP Terms of Reference

### 1. Introduction and Background

These Terms of Reference establish the objectives, scope, key assumptions, roles and responsibilities, activities, deliverables and timelines for an Integrated Regional Resource Plan “IRRP” for the Windsor-Essex region.

Based on the near- and mid-term capacity needs identified within the region, continued forecast growth in the greenhouse sector, local gas generation contracts expiring in the mid- to long-term, and opportunities for coordinating demand and supply options with end-of-life needs, an integrated regional resource planning approach is recommended.

#### The Windsor-Essex Region

The Windsor-Essex region is a summer-peaking region that includes the City of Windsor, Town of Amherstberg, Town of Essex, Town of Kingsville, Town of Lakeshore, Town of LaSalle, Municipality of Leamington, Town of Tecumseh, and the western portion of the Municipality of Chatham-Kent. The region is supplied from the Keith, Crawford, Essex, Walker #1, Walker #2, Malden, Lauzon, Kingsville, Belle River, Tilbury, Tilbury West, and Leamington transformer stations (TS). The Windsor-Essex region also includes Caldwell First Nation. The approximate geographical boundaries of the sub-region are shown in Figure A-1.

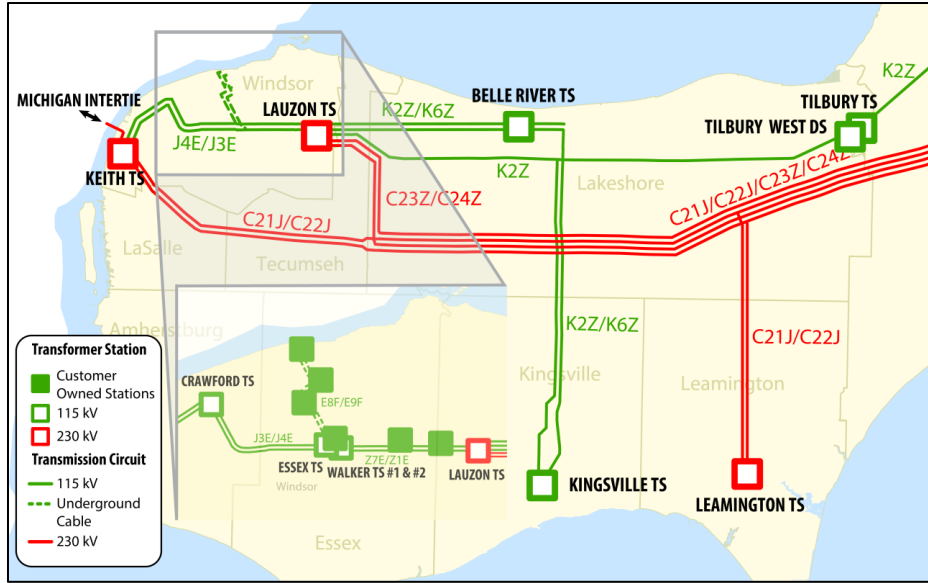

Figure A-1: Electricity Infrastructure in the Windsor-Essex Region<sup>3</sup>

Windsor-Essex Region Electricity System

The electricity system supplying the Windsor-Essex region is shown in Figure A-2.

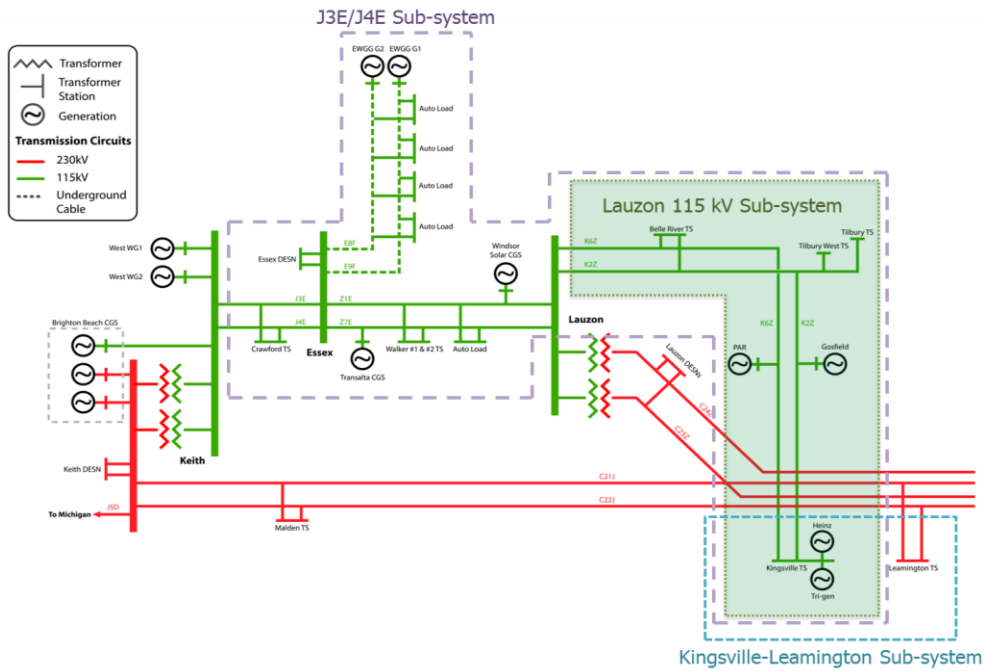

Figure A-2: Single Line Diagram of Electricity System Supplying the Windsor-Essex Region

<sup>3</sup> The region is defined by electricity infrastructure; geographical boundaries are approximate.

For study purposes, three electrical sub-systems have been identified within the Windsor-Essex region:

1. The J3E/J4E sub-system: Includes the load that would be supplied via circuits J3E and J4E for the loss of C23Z and C24Z, along with the Lauzon TS DESN loads on C23Z and C24Z which can be resupplied from the 230 kV/115 kV autotransformers post-contingency.
2. The Lauzon 115 kV sub-system: Includes the transformer stations and generators connected to circuits K2Z and K6Z.
3. The Kingsville-Leamington sub-system: Includes the load supplied by, and generation connected to, Kingsville TS or the new Leamington TS.

### Background

In May 2013 the OEB endorsed the Planning Process Working Group's report, formalizing the regional planning process. At that time, regional planning was already underway in the Windsor-Essex region. As such, the Windsor-Essex region was on one of the first regions to undergo the new regional planning process. However, due to how far planning for the region had progressed before the OEB formalized process was implemented, no formal Needs Assessment or Scoping Assessment was published in the first cycle of planning for the region.

In April 2015, the IESO published an IRRP for the Windsor-Essex region which was focused on supply to the Kingsville/Leamington sub-system and restoration of the J3E/J4E sub-system. The main recommendation of this plan was the development of a new 230 kV DESN station, Leamington TS. Subsequently, and in accordance with the OEB's process, Hydro One Transmission published the Windsor-Essex Regional Infrastructure Plan ("RIP"). In addition to reconfirming the details of Leamington TS, the RIP also recommended plans to address a number of end-of-life needs, including the replacement of the Keith autotransformers.

Since the RIP was published, the needs in the Windsor-Essex region have continued to evolve. While the 2015 IRRP had indicated that of the four end-of-life transformers at Kingsville TS only two should be replaced with 2x42 MVA units. This would have resulted in the limited time rating ("LTR") of the station decreasing from about 120 MW to approximately 60 MW. In light of the continued load growth in the area driven by expansion of greenhouse growing operations, Hydro One Distribution and Hydro One Transmission are proceeding with a plan to install 2x83 MVA units, providing a summer LTR of approximately 100 MW.

Additionally, while the RIP had indicated that the autotransformers at Keith TS should be replaced like-for-like, further discussions with Hydro One and studies completed by the IESO, which considered potential impacts to local generation in the area over the course of the



equipment's life-time, have confirmed that the incremental cost to upgrade the units at end-of-life to 250 MVA units would be justified.

In the summer of 2017, Hydro One made the IESO aware that the forecast load growth and development interest from greenhouse growers in the Leamington area was exceeding the levels identified in the 2015 IRRP and RIP. In response to the evolving near- to mid- term capacity needs in the region, the IESO and Hydro One decided to begin the next cycle of regional planning early.

Hydro One completed the Needs Assessment for the Windsor-Essex region in October 2017, identifying capacity needs, predominately at Leamington TS, and a number of sustainment and load restoration needs; some of which require boarder regional consideration. Since the Needs Assessment was published, Hydro One Distribution has continued to update their load forecast, indicating that the need date for additional capacity at Leamington TS continues to advance.

## **2. Objectives**

1. To assess the adequacy of electricity supply to customers in the Windsor-Essex region over the next 20 years.
2. To provide certainty around meeting pent-up electrical demand from greenhouse growers in the region by confirming scope and timing of required near-term infrastructure investments.
3. To integrate asset renewal needs with the sub-region's mid- to long-term capacity and reliability needs, and develop a flexible, comprehensive electricity plan for the Windsor-Essex region.
4. To develop an implementation plan that maintains flexibility in order to accommodate changes in key assumptions over time. The implementation plan should identify actions for near-term needs, preparation work for mid-term needs, and the planning direction for long-term needs.

## **3. Scope**

This IRRP will develop and recommend an integrated plan to meet the needs of the Windsor-Essex region. The plan is a joint initiative involving Hydro One Distribution, Essex Powerlines Corporation, Ewin Utilities Ltd., E.L.K. Energy Inc., Entegrus Inc., Hydro One Transmission, and the IESO, and will also incorporate input from community engagement activities. The plan will focus on the addressing near-term capacity needs in the Kingsville/Leamington sub-system, and assessing any existing or emerging restoration or supply security needs. Opportunities for end-of-life investments to aid in meeting these needs will also be explored. Like all IRRPs, in its identification or confirmation of any capacity or restoration needs, and analysis of options for

addressing end-of-life needs, the plan will integrate forecast electricity demand growth, conservation and demand management (“CDM”) in the area with transmission and distribution system capability, relevant community plans, other bulk system developments, and distributed energy resources (“DER”) uptake.

The scope of the Windsor-Essex IRRP includes the following infrastructure:

- 230 kV Connected Stations – Malden TS, Keith TS, Lauzon TS, Leamington TS
- 115 kV Connected Stations – Crawford TS, Essex TS, Walker TS #1, Walker TS #2, Belle River TS, Tilbury West HVDS, Tilbury TS, Kingsville TS
- Five customer owned transformer stations on the 115 kV system
- 230 kV Transmission Lines – C21J/C22J, C23Z/C24Z, J5D
- 115 kV Transmission Lines – J3E/J4E, Z1E/Z7E, K2Z/K6Z
- 115 kV Transmission Cables – E8F/E9F
- 230/115 kV auto-transformers at Keith TS and Lauzon TS
- Existing local generation assets

The adequacy of the bulk system supplying the area is being assessed by the IESO in parallel with this study through a separate bulk system planning process. Results of that study will be shared with the Working Group and incorporated into applicable regional studies as they become available.

Based on the identified needs, the Windsor-Essex IRRP process will consist of the following activities:

- 1) Creation of an updated 20-year demand forecast for the region.
- 2) Confirming the adequacy of transformer station ratings and the area’s load meeting capability and reliability.
  - a. Identify or confirm the transformer station capacity needs and sufficiency of the area’s load meeting capability for the study period using the updated load forecast.
  - b. Confirm identified restoration needs using the updated load forecast.
  - c. Collect information on any know reliability issues and load transfer capabilities from the Local Distribution Companies (“LDCs”).
- 3) For confirmed needs, carry out an assessment of options. Options are evaluated using decision making criteria included, but not limited to, technical feasibility, economics, reliability performance, environmental and social factors. Evaluation criteria will be informed through community engagement activities and reflect attributes deemed important to the community-at-large.

The options analysis has been divided into groupings based on the priority/timing of the needs, any known lead time information, and the depth of analysis required.

- a. Phase 1:
    - i. Identify options for meeting the near-term capacity need identified for the Leamington area and, based on the working group's recommendation, issue a hand-off letter to Hydro One.
    - ii. Confirm the load meeting capability of Kingsville TS for a winter peak.
    - iii. Determine the level of load restoration need that exists for the loss of C23Z/C24Z or C21J/C22J or K2Z/K6Z or Z1E/Z7E, as impacted by the additional capacity needs and proposed solutions for the Kingsville/Leamington sub-system.
  - b. Phase 2:
    - i. Identify options for the end-of-life step-down transformers and autotransformers at Lauzon TS.
    - ii. Identify the options for remaining transformer station capacity needs (e.g., Lauzon TS, Belle River TS), accounting for opportunities to manage load growth or upsize or re-configure facilities at end-of-life.
    - iii. Determine whether additional reinforcements to the supply to Tilbury West HVDS are required due to the decommissioning of Tilbury TS, in order to respect relevant planning criteria.
    - iv. Assess whether additional 230 kV or 115 kV system reinforcements are needed in the mid- to long-term to accommodate load growth in the Kingsville/Leamington area, or to account for expiring generation contracts, and develop a set of options as appropriate in order to respect relevant planning criteria. Outcomes of the IESO's bulk planning study should also be incorporated.
- 4) Development of the long-term recommendations and the implementation plan.
  - 5) Completion of the IRRP report documenting the near-, mid-, and long-term needs and recommendations.

In order to carry out this scope of work, the working group will consider the data and assumptions outlined in section 4 below.

#### **4. Data and Assumptions**

The plan will consider the following data and assumptions:

- Demand Data

- Historical coincident & non-coincident peak demand information for the sub-region
- Historical weather correction, for median and extreme conditions
- Gross peak demand forecast scenarios by region, TS, winter/summer, etc.
- Coincident peak demand data including transmission-connected customers
- Identified potential future load customers
  
- Conservation and Demand Management
  - LDC CDM plans
  - Incorporation of verified LDC results and progression towards OEB targets, and any other CDM programs/opportunities in the area
  - Long-term conservation forecast for LDC customers, based on sub-region's share of the 2013 Long-Term Energy Plan target
  - Conservation potential studies, if available
  - Potential for CDM at transmission-connected customers' facilities
  - Load segmentation data for each TS based on customer type (e.g., residential, commercial, industrial, agricultural) and proportion of LDC service territory within the study area
  
- Local resources
  - Existing local generation, including distributed generation ("DG"), district energy, customer-based generation, non-utility generators and hydroelectric facilities as applicable
  - Existing or committed renewable generation from Feed-in-Tariff ("FIT") and non-FIT procurements
  - Future district energy plans, combined heat and power, energy storage, or other generation proposals
  
- Relevant local plans, as applicable
  - LDC Distribution System Plans
  - Community Energy Plans and Municipal Energy Plans (e.g., Windsor Community Energy Plan)
  - Municipal Growth Plans
  - Any transit plans impacting electricity use or tied to community developments
  
- Criteria, codes and other requirements
  - Ontario Resource and Transmission Assessment Criteria ("ORTAC")
    - Supply capability
    - Load security
    - Load restoration requirements
  - NERC and NPCC reliability criteria, as applicable
  - OEB Transmission System Code
  - OEB Distribution System Code

- Reliability considerations, such as the frequency and duration of interruptions to customers
- Other applicable requirements
- Existing system capability
  - Transmission line ratings as per transmitter records
  - System capability as per current IESO PSS/E base cases
  - Transformer station ratings (10-day LTR) as per asset owner
  - Load transfer capability
  - Technical and operating characteristics of local generation
- End-of-life asset considerations and sustainment plans
  - Transmission assets
  - Distribution assets
  - Impact of on-going plans and projects on applicable facility ratings
- Other considerations, as applicable

## 5. Working Group

The core Working Group will consist of planning representatives from the following organizations:

- Independent Electricity System Operator (*Team Lead for IRRP*)
- Hydro One Transmission
- Enwin Utilities Ltd.
- Essex Powerlines Corporation
- E.L.K Energy Inc.
- Entegrus Inc.
- Hydro One Distribution

### Authority and Funding

Each entity involved in the study will be responsible for complying with regulatory requirements as applicable to the actions/tasks assigned to that entity under the implementation plan resulting from this IRRP. For the duration of the study process, each participant is responsible for their own funding.

## 5. Engagement

Integrating early and sustained engagement with communities and stakeholders in the planning process was recommended by the IESO to, and adopted by, the provincial

government to enhance the regional planning and siting processes in 2013. These recommendations were subsequently referenced in the 2013 Long-Term Energy Plan, and the focus on community and stakeholder engagement continues to be a priority in the 2017 Long-Term Energy Plan. As such, the Working Group is committed to conducting plan-level engagement throughout the development of the Windsor-Essex IRRP.

The first step in engagement will consist of meetings with municipalities and Indigenous communities within the planning area, Indigenous communities who may have an interest in the planning area, and the Métis Nation of Ontario to discuss regional planning, the development of the Windsor-Essex plan, and integrated solutions.

Municipal engagement will continue throughout the development and completion of the plan. Since agriculture is a significant source of forecast load growth for the region, engagement activities will also focus on obtaining input and feedback from greenhouse growers in the Kingsville and Leamington areas.

The Working Group will develop a comprehensive stakeholder engagement plan, according to the Activities Timeline shown in Section 6.

## 6. Activities, Timeline and Primary Accountability

**Table A-1 Summary of IRRP Timelines and Activities**

	<b>Activity</b>	<b>Lead Responsibility</b>	<b>Deliverable(s)</b>	<b>Timeframe</b>
<b>1</b>	<b>Prepare Terms of Reference considering stakeholder input</b>	<i>IESO</i>	- Finalized Terms of Reference	Jan 2018
<b>2</b>	<b>Develop the Planning Forecast for the sub-region</b>			
	Establish historical coincident and non-coincident peak demand information	<i>IESO</i>	- Long-term planning forecast scenarios	Feb – Apr 2018
	Establish historical weather correction, median and extreme conditions	<i>IESO</i>		
	Establish gross peak demand forecast and high/low growth scenarios	<i>LDCs</i>		
	Establish existing, committed and potential DG	<i>LDCs</i>		
	Establish near- and long-term conservation forecasts based on LDC CDM plans and LTEP CDM targets	<i>IESO</i>		

Activity		Lead Responsibility	Deliverable(s)	Timeframe
	Develop planning forecast scenarios - including the impacts of CDM, DG and extreme weather conditions	<i>IESO</i>		
3	<b>Provide information on load transfer capabilities under normal and emergency conditions</b>	<i>LDCs</i>	- Load transfer capabilities under normal and emergency conditions	Apr 2018
4	<b>Provide and review relevant community plans, if applicable</b>	<i>LDCs and IESO</i>	- Relevant community plans	Q2 2018
5	<b>Early Wires Planning</b>			
	Identify potential wires options to address local near-term capacity needs in the Leamington area	<i>Hydro One Transmission</i>	- Cost, feasibility and reliability performance of potential wires options - Detailed option development	Q1-Q2 2018
	Provide information on cost, feasibility and reliability performance of identified wires options for the purpose of developing integrated solutions			
6	<b>Hand off Wires Component of Integrated Solution</b>			
	Leamington TS Capacity Needs	<i>IESO</i>	- Hand-off letter to Hydro One	May 2018
7	<b>Complete system studies to identify needs over a 20-year period</b> - Obtain PSS/E base case, include bulk system assumptions as identified in the key assumptions - Apply reliability criteria as defined in ORTAC to demand forecast scenarios - Confirm and refine the need(s) and timing/load levels	<i>IESO, Hydro One Transmission</i>	- Summary of needs based on demand forecast scenarios for the 20-year planning horizon	Q2-Q3 2018
8	<b>Develop Options and Alternatives</b>			
	Develop conservation options	<i>IESO and LDCs</i>	- Develop flexible planning options for forecast scenarios	Q2-Q3 2018
	Develop local generation options	<i>IESO and LDCs</i>		

	<b>Activity</b>	<b>Lead Responsibility</b>	<b>Deliverable(s)</b>	<b>Timeframe</b>
	Develop transmission (see Action 7 below) and distribution options	<i>Hydro One, and LDCs</i>	- Deliverables staged according to the three phases outlined in section 3	
	Develop options involving other electricity initiatives (e.g., smart grid, storage)	<i>IESO/ LDCs with support as needed</i>		
	Integrate with bulk needs	<i>IESO/HONI</i>		
	Develop portfolios of integrated alternatives	<i>All</i>		
	Technical comparison and evaluation	<i>All</i>		
<b>9</b>	<b>Plan and Undertake Community &amp; Stakeholder Engagement</b>			
	Early engagement with local municipalities and Indigenous communities within study area, First Nation communities who may have an interest in the study area, and the Métis Nation of Ontario	<i>All</i>	- Community and Stakeholder Engagement Plan - Input from local communities - Input from greenhouse growers	Q2 2018
	Develop communications materials	<i>All</i>		Q3-Q4 2018
	Undertake community and stakeholder engagement	<i>All</i>		
	Summarize input and incorporate feedback	<i>All</i>		
<b>10</b>	<b>Develop long-term recommendations and implementation plan based on community and stakeholder input</b>	<i>IESO</i>	- Implementation plan - Monitoring activities and identification of decision triggers - Hand-off letters - Procedures for annual review	Q4 2018
<b>11</b>	<b>Prepare the IRRP report detailing the recommended near, medium and long-term plan for approval by all parties</b>	<i>IESO</i>	- IRRP report	Q1 2019