

HYDRO ONE TRANSMISSION GENERATION INTERCONNECTION REQUIREMENTS

Table of Contents

TERMS OF USE	2
1 INTRODUCTION	3
2 FACILITY INTERCONNECTION REQUIREMENTS	4
2.1 MINIMUM ACCEPTABLE CONNECTION BREAKER CONFIGURATION	4
2.1.1 Radial Line tap arrangement.....	5
2.1.2 Ring bus tap arrangement.....	6
2.1.3 Breaker and a half arrangement.....	8
2.2 FACILITY CONNECTION OPTIONS	9
2.2.1 Connection to a Hydro One existing substation	9
2.2.2 Connection to an existing transmission line	9
2.3 COMMUNICATION CHANNELS TO SUBSTATION	12
2.4 PROXIMITY OF HYDRO ONE AND CUSTOMER SUBSTATIONS	12
2.5 DEMARCATION AND OWNERSHIP	12
3 PERFORMANCE AND DESIGN REQUIREMENTS	13
3.1 GENERAL REQUIREMENTS	13
3.2 ANTI-ISLANDING REQUIREMENTS	13
3.3 POWER QUALITY	13
3.4 GROUNDING	14
3.5 EQUIPMENT RATINGS	15
3.6 INSULATION COORDINATION	15
3.6.1 Lightning Surges.....	16
3.6.2 Switching Surges.....	16
3.6.3 Temporary Over-voltages.....	16
3.7 SYNCHRONIZING CAPABILITIES	17
3.8 ELECTRICAL DISTURBANCES REQUIREMENT.....	18
3.8.1 Air-break disconnect switch duty under capacitive and inductive currents	18
3.8.2 Circuit breaker duty.....	18
4 INTERCONNECTION STUDY REQUIREMENTS AND OTHER CONSIDERATIONS	19
4.1 GENERAL STUDIES	19
4.2 PROTECTIVE RELAY COORDINATION STUDIES (DURING EXECUTION).....	20
4.3 INSULATION COORDINATION STUDIES, BIL & SURGE PROTECTION SPECIFICATION	20
4.4 CONTINGENCY AND REMEDIAL ACTION SCHEME (RAS) REQUIREMENTS	21
5 TESTING AND INSPECTION	22
6 DISTURBANCE MONITORING REQUIREMENTS	23
APPENDIX A: LIST OF ACRONYMS	24
APPENDIX B: RELEVANT LINKS	25

HYDRO ONE TRANSMISSION GENERATION INTERCONNECTION REQUIREMENTS

TERMS OF USE

This document is being provided by Hydro One Networks Inc. ("Hydro One") for information purposes to owners and operators of new generation facilities interconnecting to the Hydro One transmission system or existing facilities that are modified resulting in an increase in MW name-plate rating of any of the connected units. The owners' and operators' use of the information in this document is their acknowledgment and agreement that: (a) Hydro One makes no representations or warranties (express, implied, statutory or otherwise) as to this document or its contents; (b) the owners' and operators' employees, directors and agents (the "Representatives") shall be responsible for the protection of their equipment in respect of their use of the document and any conclusions derived from its contents; and (c) Hydro One will not be liable for any damages resulting from or in any way related to the reliance on, acceptance or use of the document or its contents by the owners and operators and their Representatives for the protection of their equipment.

HYDRO ONE TRANSMISSION GENERATION INTERCONNECTION REQUIREMENTS

1 INTRODUCTION

The objective of this document is to specify and identify requirements applicable to interconnecting new generation facilities seeking connection to Hydro One's HV (high voltage - up to 230kV) and EHV (extra high voltage – 500kV) Transmission System. Bulk Electric System (BES) performance requirements span across multiple standards and the scope of this document is to capture requirements that help avoid or minimize adverse impacts of the new connection, while ensuring reliable operation over a broad spectrum of system conditions. Generation interconnecting Facilities seeking connection to the Hydro One transmission system shall comply with the requirements specified in this document in accordance with NERC Std. FAC 001.

In addition to these requirements, Hydro One may also assess other factors, such as, but not limited to, the type of technology of the Generation Interconnecting Facility, location where the facility is interconnecting, existing generation facilities where the new facility is interconnecting, and future plans to ensure minimum connection configuration is adequate without any adverse impact on the transmission system or other connected customers. Throughout this document, a Generation Interconnecting Facility will be interchangeably referred to as an Interconnecting Facility.

The proponent of the new generation facility shall provide the requested information, specifications and required studies of its connection facilities, as well as a detailed execution plan as part of [Hydro One connection application process](#) for assessment and coordination to interconnect to Hydro One system. Hydro One shall be immediately notified of any modifications to the technical specifications proposed by the Generation Interconnecting Facility. Hydro One shall at its discretion perform a review of the required interconnection studies prior to granting permission to interconnect the proposed project.

Interconnecting generation facilities shall also comply with other applicable Codes, standards, guidelines, and requirements from OEB, IESO, NERC, NPCC, and CSA that are not listed in this document (refer to Appendix B Relevant Links).

All connection costs triggered by the interconnecting generation shall be the responsibility of the Interconnecting Facility owner.

HYDRO ONE TRANSMISSION GENERATION INTERCONNECTION REQUIREMENTS

2 FACILITY INTERCONNECTION REQUIREMENTS

2.1 MINIMUM ACCEPTABLE CONNECTION BREAKER CONFIGURATION

Minimum connection configuration requirements are displayed in Table 2-1 for each transmission voltage level. Single line diagram for the new generation interconnection facility illustrating the minimum acceptable connections for each voltage level (ring bus, breaker and a half) are shown below.

Table 2-1: Summary of acceptable bus breaker configuration based on facility rated capacity for connection to transmission line or substation¹

Voltage Level (kV)	Connection Point	Typical Maximum Generation Capacity allowed per Line (MW) ²	Minimum Connection Configuration
115	Single Radial and Terminal to Terminal Line	Up to 75 MW or existing line available capacity (whichever is more limiting)	Line Tap Fig 2-1
230	Single Radial Line Connection	Up to 300 MW or existing line available capacity (whichever is more limiting)	Line Tap Fig 2-1
230	Dual Radial Line Connection	Up to 300 MW each line or existing line available capacity (whichever is more limiting)	3 Breaker Arrangement Fig 2-2
230	Single Terminal to Terminal Line Connection	Up to 300 MW or existing line available capacity (whichever is more limiting)	Ring Bus Fig 2-3
230	Dual Terminal to Terminal Line Connection	Up to 300 MW each line or existing line available capacity (whichever is more limiting)	6 breaker ring bus Fig 2-4
500 ³	Line	Minimum 600 MW and up to existing line available capacity, (whichever is more limiting)	Full Switching station with a Breaker and a half configuration Fig 2-5

¹ Connection to switching substation will be studied on a case by case basis to determine a maximum connection capacity

² The maximum connection capacity is based on a typical thermal limitation of a line at each voltage level and does not account for any existing generation connected to the line. It is expected that the maximum typical generation can be connected before special assessments are needed.

³ 500 kV circuits are critical to security of the Ontario electricity system. Hence, generation connection to 500kV lines is generally not allowed and may only be considered at Hydro One's discretion when there are no other technically feasible options for connection at 115kV or 230kV.

HYDRO ONE TRANSMISSION GENERATION INTERCONNECTION REQUIREMENTS

2.1.1 Radial Line tap arrangement

A radial line tap configuration is when a generator connects to the transmission line without sectionalizing the line through a single isolating breaker near the transmission line. This method is the least costly but provides no flexibility in operation. A breaker failure of the generator's HV breaker can take the transmission line out of service until the HV disconnect switch is open. This configuration is only allowed when the generator is connected near the end of a radial circuit. Figure 2-1 and 2-2 illustrates a sample direct line tap connection for a single circuit and to dual circuits.

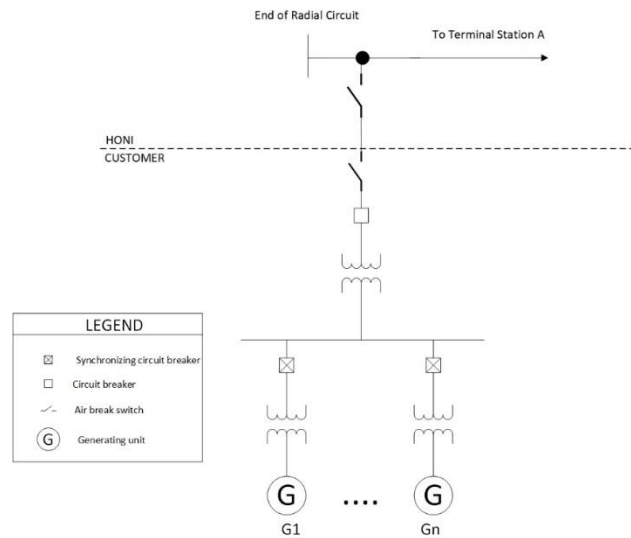

Figure 2-1 Generation interconnection facility in a line tap configuration connected to a radial single circuit

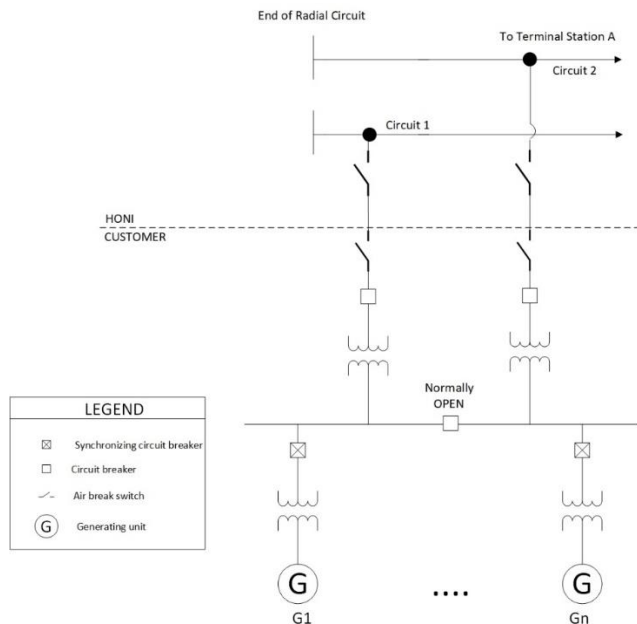

Figure 2-2 Generation interconnection facility in a 3 breaker configuration connected to two radial circuits

HYDRO ONE TRANSMISSION GENERATION INTERCONNECTION REQUIREMENTS

2.1.2 Ring bus tap arrangement

A ring bus tap configuration is a variation of the line tap arrangement where the line is sectionalized using a 3 breaker ring bus. This results in a closed loop, thus the name “ring”, with each section separated by a circuit breaker.

This design provides immunity to the main circuit de-energization in the event of generator circuit breaker failure. Under those conditions, only the breakers near the failed element need to open, thus minimizing loss of circuits. This arrangement also provides maintenance flexibility since each circuit breaker can be removed from service at the time without the loss of any circuits. The conversion of ring bus configurations to more reliable designs (such as breaker and a half) can be done with relative ease. A typical ring bus tap configuration is shown in Figure 2-3 and 2-4.

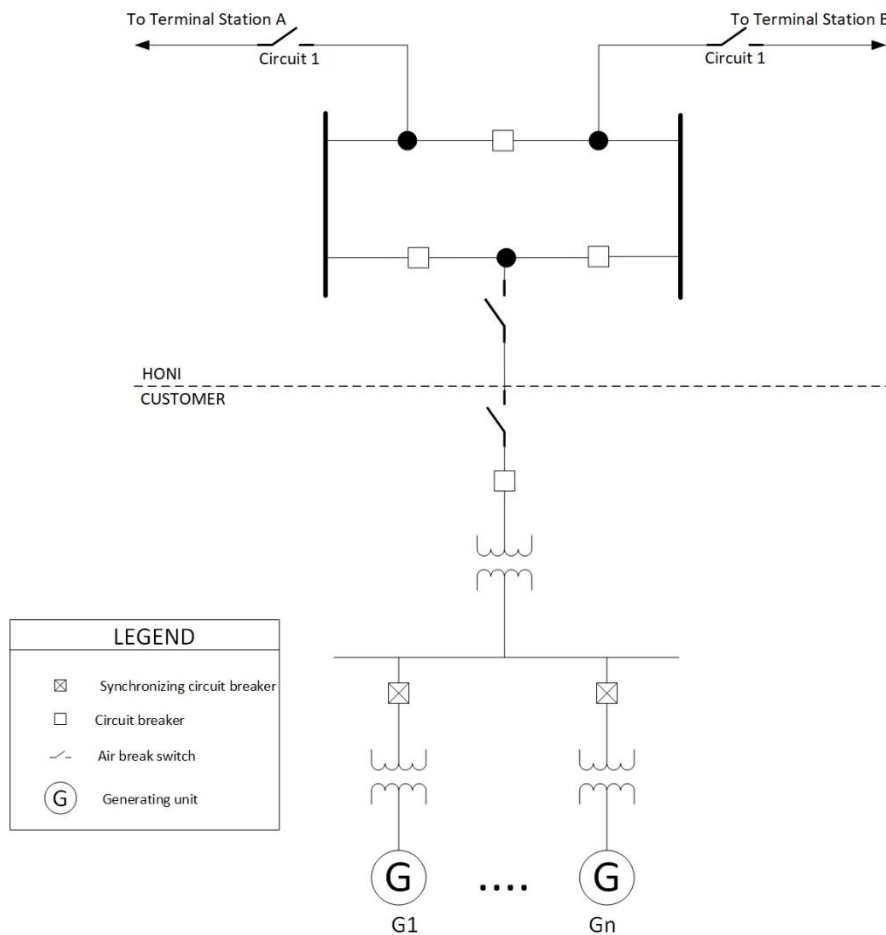

Figure 2-3 Generation interconnection facility in ring bus configuration connected to a single circuit

HYDRO ONE TRANSMISSION GENERATION INTERCONNECTION REQUIREMENTS

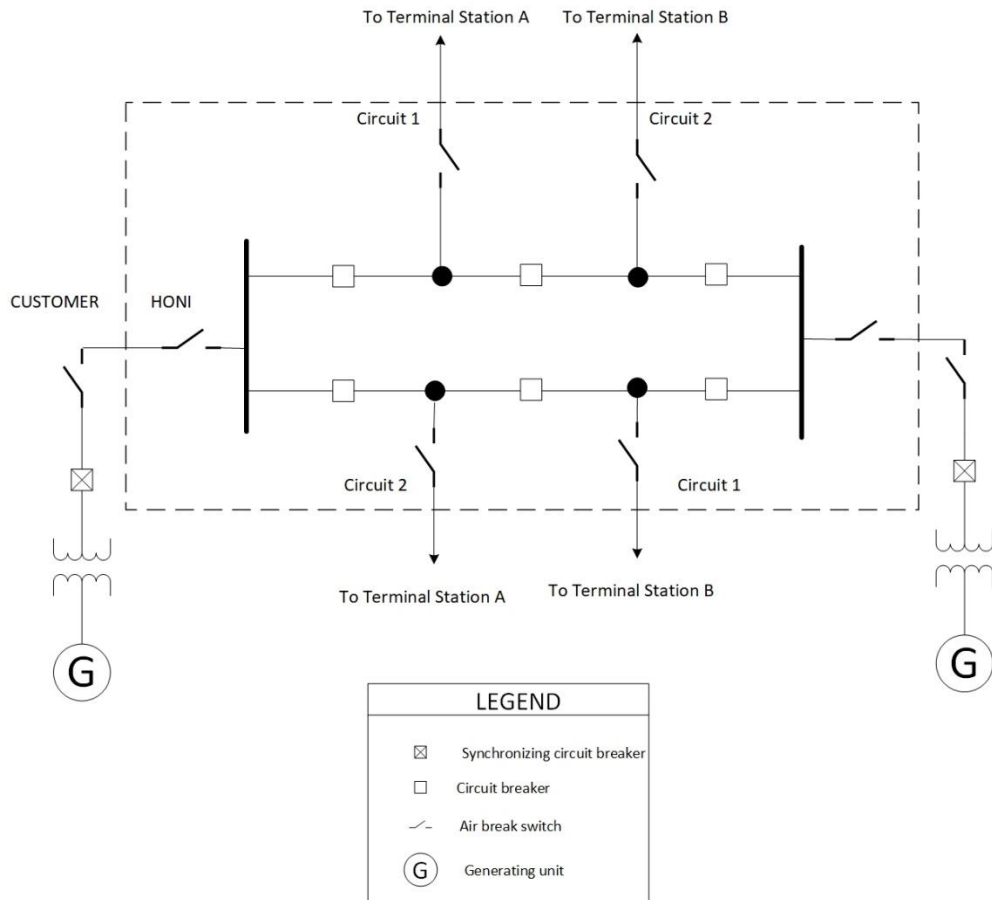

Figure 2-4 Generation interconnection facility in a 6 breaker ring bus configuration connected to two circuits

HYDRO ONE TRANSMISSION GENERATION INTERCONNECTION REQUIREMENTS

2.1.3 Breaker and a half arrangement

A breaker and a half configuration consists of two main buses, which are both normally energized and connected to each other through strings of breakers. Three or more circuit breakers are connected on each string between the two buses to establish two connection positions. Multiple breaker bays can be added depending on the number of circuits interconnecting at the substation. Each breaker bay normally accommodates two circuits, although designs with more breakers are also possible.

This design allows the removal of any breaker from service without the interruption of any circuit. Additionally, faults on either of the main buses can be isolated without causing any circuit interruptions. Failure of a circuit breaker results in the loss of two circuits if a common breaker fails and only one circuit if an outside breaker fails.

A typical breaker and a half design is shown in Figure 2-5.

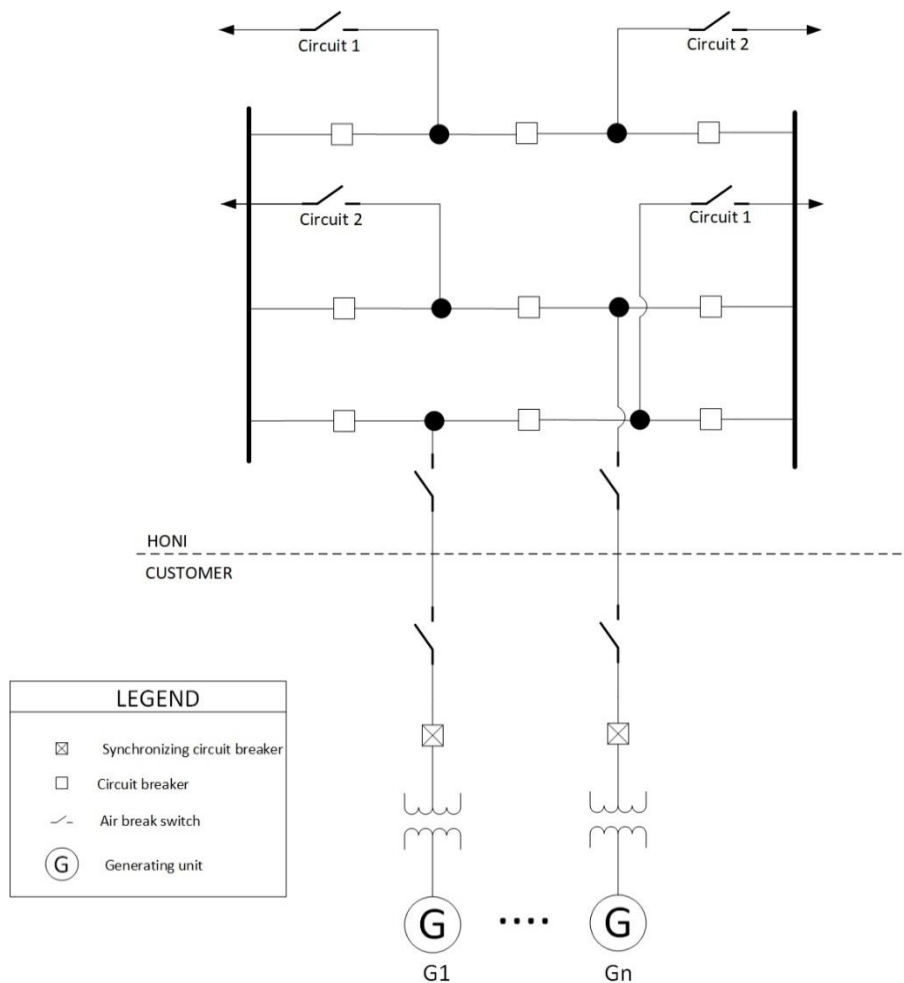

Figure 2-5 Generation interconnection facility in breaker and a half configuration

HYDRO ONE TRANSMISSION GENERATION INTERCONNECTION REQUIREMENTS

2.2 FACILITY CONNECTION OPTIONS

There are two main options for a Generation Interconnecting Facility to connect to the transmission system: connection to a substation (new or existing) or connection to a transmission line (new or existing). Upon completion, all equipment that is inside Hydro One's ownership zone, indicated along the point of change of ownership line in Figure 2-, Figure 2- and Figure 2-3, shall be transferred to Hydro One.

2.2.1 Connection to a Hydro One existing substation

If a Generation Interconnecting Facility is connecting to an existing substation, the bus breaker arrangement of the Interconnecting Facility must follow the same scheme employed at the substation it is interconnecting into, regardless of the station rated voltage levels. If a ring bus type breaker arrangement is used, connection may be limited to a maximum number of elements (e.g., four or five). In cases where the maximum number of permitted connections is exceeded, the substation breaker arrangement shall be converted to a more reliable breaker arrangement (e.g., breaker and a half bus configuration). Hydro One will determine suitable bus-breaker arrangements on a case by case basis. The proposed connection configuration shall also be assessed and approved by the IESO.

2.2.2 Connection to an existing transmission line

If an Interconnecting Facility is connecting to a transmission line, two main connection types are permitted: line tap with a breaker or connection via a new switching station. Line tap connections with an isolating breaker are allowed up to 115 kV transmission network and for generation plant rating less than 75MW. Ultimately, Hydro One shall reserve the right to evaluate line tap proposal to determine if the construction of a new switching facility is required.

Line tap connections to the 230kV system and above are not permitted for network lines. For facilities connecting to the 230kV or 500kV system, connection via a new switching station is required to ensure operability and maintainability of the transmission system.

For facilities connecting to the 230kV system, the minimum acceptable breaker configuration is a ring bus scheme. For facilities connecting to the transmission system at voltages rated 500kV and above, a full switching station with a breaker and a half scheme is the minimum acceptable configuration. Typical Maximum Interconnecting Facility sizes at different voltage levels are shown in Table 2-1. Connection to any switching substation will be studied on a case by case basis to determine a maximum connection capacity in each case.

HYDRO ONE TRANSMISSION GENERATION INTERCONNECTION REQUIREMENTS

Whenever feasible, the new switching station built to connect the Generation Interconnecting Facility to a transmission line must take place along or as close as possible near the transmission line right of way, as shown in Figure 2-6. If the facility is distant from the transmission line, an extended line connection as shown in Figure 2-7 is also permitted. In this case, the extended line ratings must be such that under the loss of an extended circuit, the full plant capacity can still be exported through the remaining extended circuit.

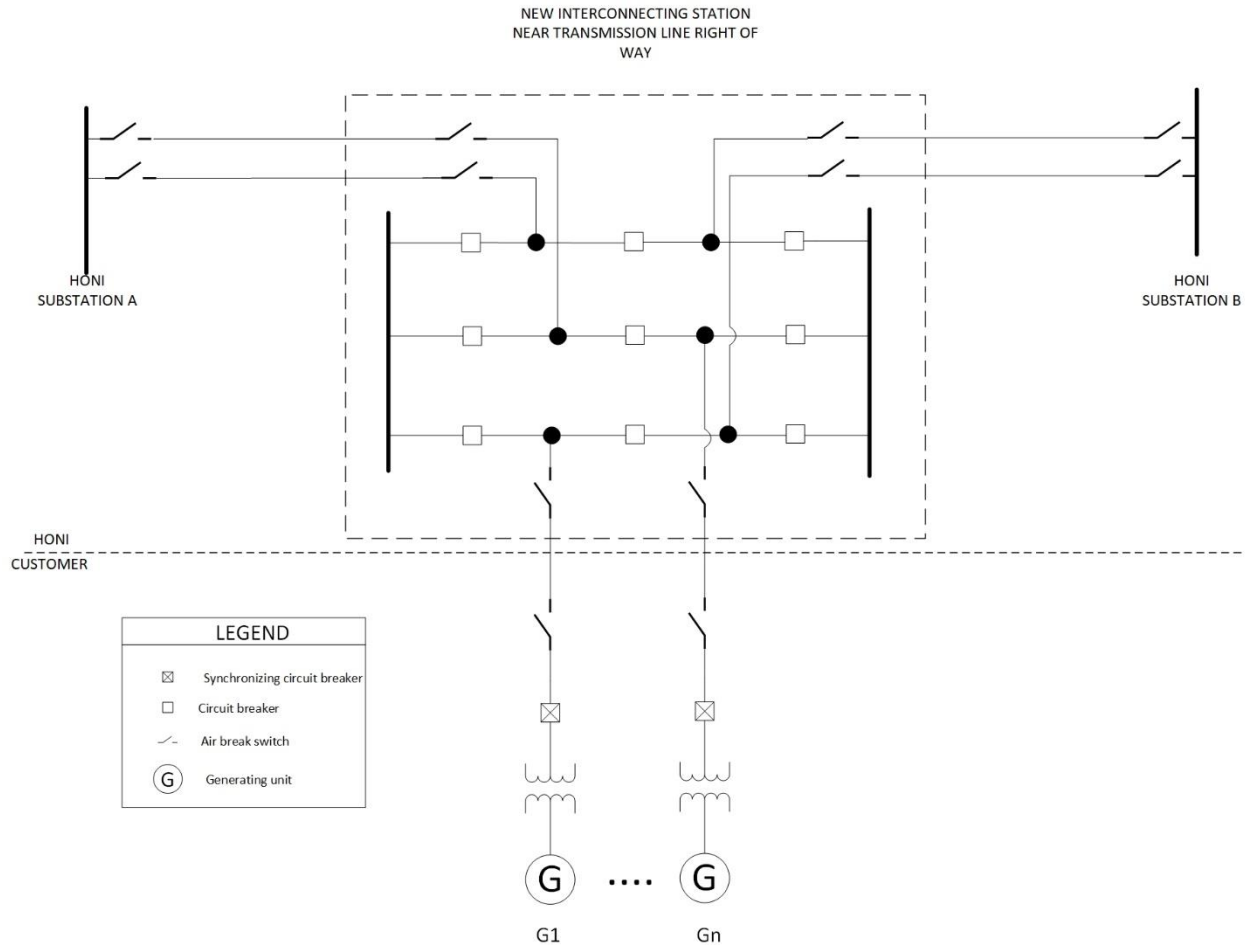

Figure 2-6 Generation Interconnecting Facility built near the transmission line right of way using breaker and a half configuration

HYDRO ONE TRANSMISSION GENERATION INTERCONNECTION REQUIREMENTS

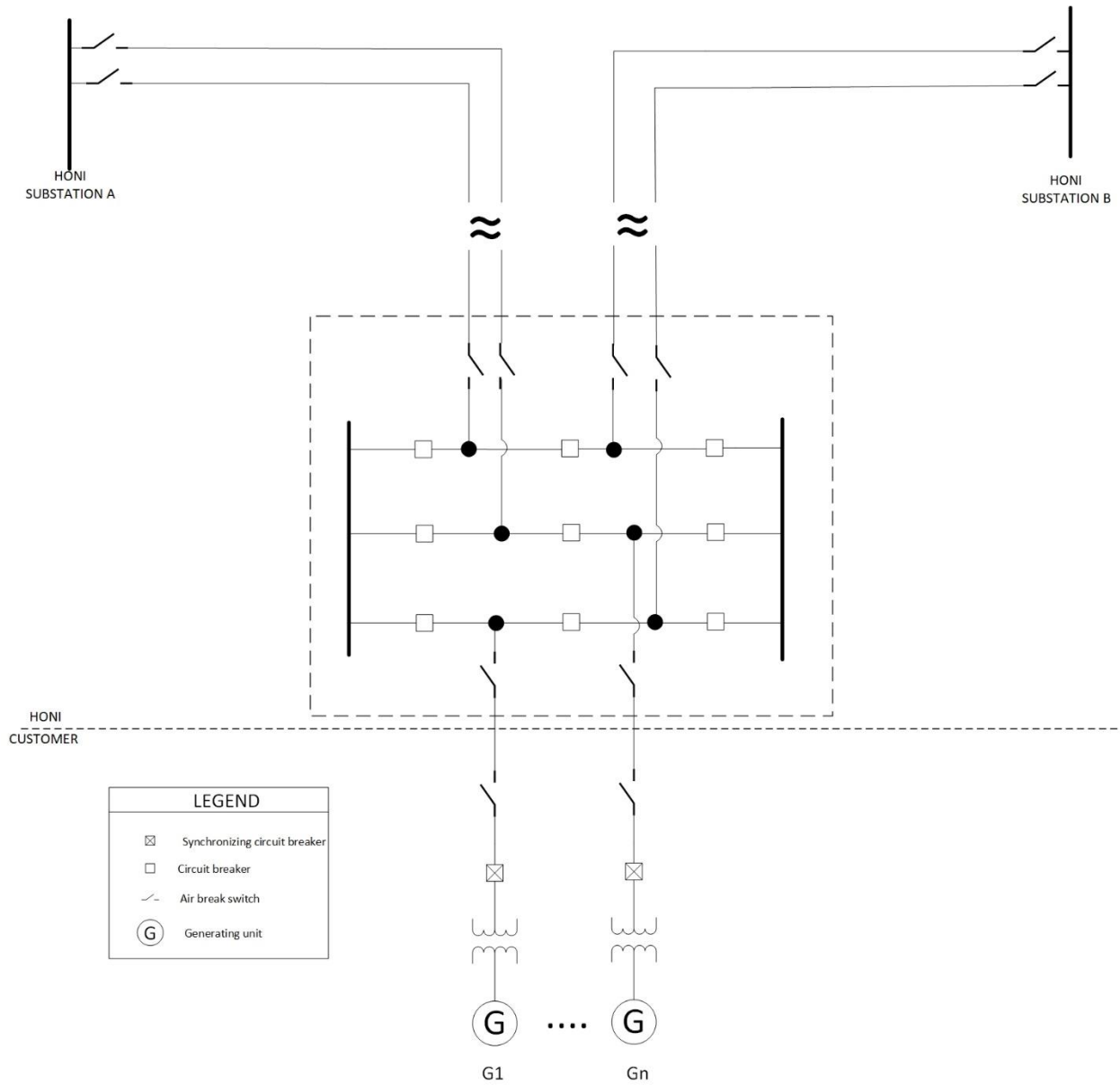

Figure 2-7 Generation Interconnecting Facility built with extended lines using breaker and a half configuration

HYDRO ONE TRANSMISSION GENERATION INTERCONNECTION REQUIREMENTS

2.3 COMMUNICATION CHANNELS TO SUBSTATION

Redundant communications channels shall be installed and maintained between the Generation Interconnecting facility and the Transmission Station/Switching Station. These channels will be used for all control, relay and any transfer trip signals, as well as other communication needed to operate and provide visibility to Hydro One into the Generation Interconnecting Facility. If the connection is to a transmission line or substation that is NPCC impactive, then physically diverse path for main and alternate communication channels is required. This shall be determined on a case by case basis by Hydro One and the IESO as part of the System Impact Assessment and design stage.

Protection and control may require fiber optical or radio communications if hardwiring is not practical. The new Interconnecting Facility will own the circuit breakers, relays and all additional protection and control equipment located within their facility. The new Interconnecting Facility is responsible for synchronizing and protecting its devices from system disturbances outside the substation they are connecting to.

2.4 PROXIMITY OF HYDRO ONE AND CUSTOMER SUBSTATIONS

The proximity between the Hydro One interconnection substation and the customer substation will determine the protection scheme employed at the interconnecting element(s) between the substations. A bus protection scheme will be employed for Customer's substation built near Hydro One's interconnection substation as the electrical connection between the two substations will be considered a bus extension. If the two substations are not adjacent or in proximity, a line protection scheme will be generally employed. [Hydro One PP-60000-003 R1](#) provides Protection Planning Standards for transmission to generation interconnection and shall be used as a guideline and reference for protection design.

2.5 DEMARCATION AND OWNERSHIP

The Point of Interconnection (POI) will be defined as the point at which the Generation Interconnecting Facility connects to the transmission system. The point of change of ownership (PCO) will be typically at/near the jaw side of the motorized disconnect switch which connects the customer's substation to the dead-end structure of Hydro One's transmission connection facilities. Customer owned assets (e.g. Surge arrestors) shall not be connected to Hydro One's side of ownership. Examples of PCO are indicated by the dashed boundaries between Hydro One's and Customers stations in Figure 2-, Figure 2- and Figure 2-3.

HYDRO ONE TRANSMISSION GENERATION INTERCONNECTION REQUIREMENTS

3 PERFORMANCE AND DESIGN REQUIREMENTS

3.1 GENERAL REQUIREMENTS

Connection of generating facilities to Hydro One's HV and EHV system must follow requirements of Ontario Energy Board's Transmission System Code, Market Rule, and Hydro One and applicable standards.

The generation Interconnecting Facility shall be able to independently synchronize with Hydro One's transmission network without support from Hydro One. If the Hydro One owned facility is de-energized, the customer shall not take actions to re-energize the facility unless directed to do so and authorized by Hydro One and the IESO.

The facility shall not cause interference with the electric service provided to other customers or adversely impact the security of the system. To minimize adverse impacts and comply with local, regional and national industry standards, the new interconnecting facility shall meet the performance requirements of IESO's Market Rules, Appendix 4.2 (refer to Appendix B Relevant Links), which covers the following categories:

3.2 ANTI-ISLANDING REQUIREMENTS

A generating Interconnecting Facility shall not be allowed to island from the rest of the system and continue to serve other customers in an islanded operation fashion, unless specified, coordinated, and approved in advance by the IESO and Hydro One. Generation interconnecting facilities are allowed to disconnect from the rest of the transmission network and operate islanded only while serving its auxiliary loads.

3.3 POWER QUALITY

3.3.1 Self-Excitation and Resonance Phenomena

The risk of self-excitation of generators shall be evaluated by the Interconnecting Facility and reported to Hydro One. Protective measures to mitigate self-excitation and resonance shall be implemented to avoid their occurrence. The Generator Owner shall work with Hydro One to devise appropriate measures to address any concerns at the design stage by implementing necessary mitigations and during operation, if necessary.

3.3.2 Power Quality Monitoring

The installation of power quality monitoring devices shall be performed to ensure data is collected and shared with Hydro One. High-speed sampling rates shall be available to capture phenomena across a wide range of system timeframes, voltage and current levels. Measurements collected by power quality meters will increase awareness and allow Hydro One to assess various aspects related to power quality at the Interconnecting Facility.

HYDRO ONE TRANSMISSION GENERATION INTERCONNECTION REQUIREMENTS

Power Quality shall be characterized in accordance with measurements and practices specified in [CAN/CSA-IEC 61000-4-30](#) and [IEC/TS 62749 “Assessment of Power Quality – Characteristics of Electricity Supplied by Public Networks”](#)

3.3.3 Harmonics

The Interconnecting Facility shall not cause excessive voltage fluctuations, flicker, and harmonic distortion or introduce any type of voltage or current injections that substantially degrade the fundamental frequency waveform in the transmission system. Interconnecting facility equipment shall not form a resonant circuit with the transmission system at harmonic frequencies. All Hydro One, IESO, NPCC and NERC power quality requirements and/or standards must be met. The Interconnecting Facility shall comply with harmonic voltage and current limits specified in [IEEE Standard 519-1992, "IEEE Recommended Practices and Requirements for Harmonic Control in Electrical Power Systems"](#).

When applicable and required, [IEEE Std 1453-2004, "IEEE Recommended Practice for Measurement and Limits of Voltage Fluctuations and Associated Light Flicker on AC Power Systems"](#) provides guidance regarding how flicker can be measured at the facility. A measure of short-term perception of flicker (pst) shall be obtained for a ten-minute interval. A measure of long-term perception of flicker (plt) shall be obtained for a two-hour period calculated from 12 consecutive pst values. The connected facility shall be designed and operated such that pst does not exceed 0.8 and plt does not exceed 0.6 for more than 1% of the time (99% probability level) using a minimum assessment period of one week.

3.4 GROUNDING

The grounding system at the interconnecting substation shall be designed to provide personnel safety as well as to avoid permanent damage on certain system components, as per Ontario Electrical Safety Authority (ESA) requirements. [ANSI/IEEE 80](#) shall be used as a reference to design the Interconnecting Facility grounding grid and aimed at addressing two main requirements:

To ensure that step and touch potential hazards remain below permissible limits throughout the facility, and risk of transfer potentials remains adequately managed. Hydro One will review the designed grounding scheme to ensure that it will provide proper protection to Hydro One's facility. Any network upgrade required by the interconnection of the new facility will be defined at the design stage and the customer must provide short circuit rated interconnection facilities not lower to those specified by Hydro One.

HYDRO ONE TRANSMISSION GENERATION INTERCONNECTION REQUIREMENTS

The new Interconnecting Facility and Hydro One will design their substation ground grid separately and both grids will be designed to withstand the highest fault current identified by Hydro One. The identification of the highest short circuit current will be based on short circuit studies at the Interconnecting Facility. Both the Interconnecting Facility and Hydro One ground grid design must meet safety standards regarding safe touch and step potential hazards as a standalone grid (i.e., it shall meet all grounding requirements using solely its own ground system). The grids must also meet all grounding requirements along the boundary between the substations if they are electrically close and where the ground grids may be connected to each other.

The facility owner is responsible for including Hydro One during the grounding grid design stage for review of its impact on Hydro One facilities. Failure to do so may lead to designs that are not acceptable by Hydro One and may delay project approval.

3.5 EQUIPMENT RATINGS

All equipment ratings must meet applicable standards and requirements. These include, but are not limited to, the following: basic impulse insulation (BIL) levels, maximum continuous operating voltages, maximum continuous currents, surge arrester parameters, among other ratings.

The customer shall size its Interconnecting Facility to appropriately satisfy the requirements put forth by Hydro One and ensure that it is adequate for connection to Hydro One's existing facility. Hydro One and the customer shall exchange information and communicate on a regular basis prior the commercial operation date or implementation of any additional modifications to existing design plans. Some of these discussions include the identification of the most limiting hardware component. The customer shall implement additional modifications to existing design plans if required. Additional NERC, NPCC and IESO standards related to equipment rating requirements also apply.

3.6 INSULATION COORDINATION

Various events can give rise to stressed conditions that may expose and damage equipment, such as lightning strikes, temporary overvoltage due to switching operations, faults and their clearing, etc. Hydro One has existing guidelines on insulation requirements and surge protection and any interconnecting facility shall not degrade or adversely impact the degree of protection that is currently provided. Therefore, all new interconnecting facilities shall have lightning, temporary overvoltage and switching performances that meet or exceed requirements applicable to existing Hydro One equipment.

All new stations of interconnecting facilities shall be fully shielded. All transmission lines that enter the station shall be shielded. Surges arresters may be required in order to achieve proper insulation coordination and provide adequate safety and security to substation equipment.

HYDRO ONE TRANSMISSION GENERATION INTERCONNECTION REQUIREMENTS

The interconnection of new facilities may change the frequency at which the equipment is exposed to stress or the intensity of the stress. Changes and upgrades of devices such as switchgear, shielding, grounding, wires, communication, surge protective devices, among other things, may be required. To identify potential upgrades required, Hydro One may perform a series of studies to quantify any potential condition where the stress on equipment has increased.

3.6.1 Lightning Surges

All HV and EHV lines shall be shielded. Transmission tower grounding impedances shall meet Hydro One design standard. Hydro One may require surge protective devices installed at line entrances in order to protect station equipment from potential surges caused by lightning that may enter the station through the line.

3.6.2 Switching Surges

Hydro One may require surge arresters installed or other strategies to mitigate or manage lightning and switching surges that may arise on some HV and EHV circuits. The need for switching surge mitigation schemes will depend on the susceptibility of new interconnecting facilities to operate normally during switching surges. If any interconnecting facility is susceptible to misoperation, failure or disconnection due to switching surges identified at its location, the facility owner will be responsible for proposing mitigation and its associated installation costs.

3.6.3 Temporary Over-voltages

Temporary over-voltages can last from a few cycles to minutes and are not characterized as surges. These over-voltages are present during islanding, faults, loss of load, or long-line situations. All new and existing equipment shall be capable of withstanding these duties.

They are expected to survive expected system temporary over-voltages. Extremely high temporary over-voltage that may damage the surge arresters shall be avoided by design.

3.6.3.1 Neutral Shifts

Neutral shifts can arise from various conditions ranging from poorly grounded systems to ungrounded systems. Its impact can range from reduced personnel safety to voltage differentials at stations as well as increased risk of equipment damage. To mitigate the potential for neutral shifts, overvoltage or unsafe station voltages, the interconnecting facility shall implement several practices currently enforced by Hydro One in its transmission and substations. Suggested actions to mitigate the occurrence and impact of neutral shifts are discussed below.

HYDRO ONE TRANSMISSION GENERATION INTERCONNECTION REQUIREMENTS

3.6.3.2 Effectively Grounded System

Effectively grounded systems will reduce the risk of damage to surge arresters and other system equipment. The use of grounded-wye transformer connections on the high voltage side shall provide adequate grounding and help mitigate the issue. Example of transformer connections commonly used to provide effective ground on the high-voltage side of a transmission system include the following:

- A transformer with the high voltage side (transmission) side in grounded-wye and low voltage side (equipment side) connected in delta.
- Transformer with primary winding side and secondary winding side connected grounded-wye and an additional lower voltage tertiary winding connected in a delta.

3.6.3.3 Increased Insulation Levels

When system grounding is not effective or can't be improved, another approach to address overvoltage concerns is to increase the level of insulation required by equipment. Higher insulation levels would need to be applied to remote line terminals and any stations tapped to the transmission line. The higher insulation level shall help the equipment withstand the higher amplitude and duration of voltages that may arise from neutral shifts. All switchgear that interrupts faults or load supplied from an ungrounded transformer winding shall be capable of withstanding increased recovery voltages.

3.6.3.4 High Speed Separation

High speed breaker operation with remote sensing (transfer trip) or local sensing of overvoltage conditions may also effectively help reduce overvoltage duration from neutral shift events. Hydro One shall evaluate and review proposed methods to ensure that there are no violations of equipment insulation withstand capabilities.

3.7 SYNCHRONIZING CAPABILITIES

Interconnecting Facilities which are synchronous machines shall be able to self-synchronize with the main grid when connecting to Hydro One facilities. The synchronization shall be performed with the use of synchronizing relays. The automatic synchronization shall be supervised by a synchronizing check relay to ensure that generating units are not connected to the grid out of synchronization.

HYDRO ONE TRANSMISSION GENERATION INTERCONNECTION REQUIREMENTS

3.8 ELECTRICAL DISTURBANCES REQUIREMENT

The Interconnecting Facility shall be expected to withstand, within design limits, a wide variety of conditions that may arise during normal operation or switching. This includes daily capacitor bank switching. Additionally, the Interconnecting Facility shall not exceed design criteria related to certain phenomena, some of which are listed below.

- Electric system disturbances that produce abnormal power flows (NERC Std. FAC-002 and FAC-008)
- Over-voltages and under-voltage (NERC Std PRC-024)
- Over-frequency and under-frequency (NERC Std PRC-024)
- Resonance
- Power system faults and equipment failures
- Audible noise, radio, television and telephone interference (IEEE Std. 430)
- Power system harmonics (IEEE Std. 519)
- Other disturbances that might degrade the reliability of the interconnected system

3.8.1 Air-break disconnect switch duty under capacitive and inductive currents

The ability of air-break disconnect switches in interrupting small capacitive or inductive currents shall be confirmed by the Interconnecting Facility and reported to Hydro One.

3.8.2 Circuit breaker duty

An interconnecting facility may increase circuit breaker interrupting duty in terms of short circuit current and transient recovery voltage. Circuit breaker duty shall be verified and examined through studies to ensure that existing breakers at the new Interconnecting facility or nearby will be able to break fault current as per the limits set out in the TSC.

HYDRO ONE TRANSMISSION GENERATION INTERCONNECTION REQUIREMENTS

4 INTERCONNECTION STUDY REQUIREMENTS AND OTHER CONSIDERATIONS

4.1 GENERAL STUDIES

The Interconnecting Facility must provide the necessary data for a SIA study which is performed by the IESO. A SIA involves a series of interconnection studies including, but not limited to, power flow, short circuit, protection impact and stability.

Hydro One will perform a transmission CIA study to evaluate the impact of the Interconnecting Facility on its transmission system connected customers. More details about data requirements, milestones, scope and timeframes can be obtained at Hydro One's website.

Special studies and/or assessments may be required by Hydro One depending on the characteristics of the type of resource connecting to the transmission system, connection configuration, as well as the location where it is interconnecting. For inverter-based resources (IBRs) (e.g., wind, solar, battery energy storage systems, STATCOMs, SVCs, etc), Hydro One may request additional studies to ensure that system reliability will not be adversely impacted by the Interconnecting Facility.

Examples of these special studies include, but are not limited to, the following:

- Control interactions between multiple nearby power electronic or converter-interfaced devices (type 3 or 4 wind machines, solar PV, HVDC, STATCOM, SVC, etc.)
 - Sub-synchronous oscillations studies (SSO studies), particularly if a combination of the following devices, which are known to increase the risk of SSOs, is found near the Interconnecting Facility or the area.
 - Type 3 (doubly fed induction generator) wind plants
 - HVDC transmission lines (both LCC and VSC technologies)
 - Series compensated lines with Fixed Series Capacitor Banks (FSCB) or Thyristor Controller Series Capacitors (TCSC).
 - Any other device that may create a risk for SSOs
 - Fault ride through performance verification (e.g., to support FERC Order 828, [NERC PRC-024-2](#), etc.). The intent of this analysis is to ensure that the Interconnecting Facility does not trip when it is not supposed to trip.
 - Reactive power coordination studies among nearby plants for devices connecting to an area with low short circuit strength. These include, but are not limited to, control interaction between voltage regulating devices that are electrically close to each other,
-

HYDRO ONE TRANSMISSION GENERATION INTERCONNECTION REQUIREMENTS

- Power quality and harmonic analysis studies including identification of total levels of harmonic distortion, and other applicable power quality topics (voltage sag, swell, transients, etc). This is mainly applicable to power electronic or converter interfaced devices (type 3 or 4 wind machines, solar PV, HVDC, STATCOM, SVC, etc.)

4.2 PROTECTIVE RELAY COORDINATION STUDIES (DURING EXECUTION)

Detailed protective relay coordination studies shall be performed by the Interconnecting Facility and reviewed by Hydro One. [NERC standard PRC-001](#) specifies the roles and requirements applicable to each party involved in the coordination effort and shall be used as a reference, in addition to other applicable NPCC and IESO requirements. These studies shall account for all nuances related to each facility and its location and must be a coordinated effort between the new Generation Interconnecting Facility (Generator Owner) and Hydro One.

For IBR plants, detailed EMT models of the interconnecting facilities shall be submitted to Hydro One. These models shall provide an accurate representation of the controls and protection features of the plant. The model shall be used in various types of studies to demonstrate plant compliance with the various requirements specified in this document as well as other NERC, IESO and NPCC standards. Examples of studies to be performed include voltage ride through, plant stability, voltage control, frequency control, transient performance, harmonic studies, among others.

4.3 INSULATION COORDINATION STUDIES, BIL & SURGE PROTECTION SPECIFICATION

The Interconnecting Facility shall perform insulation coordination studies to determine the adequate level of electrical insulation to be installed and coordinated with overvoltage protection. These studies must consider existing requirements set forth by Hydro One in existing design specification documents.

Surge arresters shall be designed to provide adequate protection against system events and their performance shall meet or exceed existing [IEEE 1862-2014](#) and [ANSI/NEMA C29.12-2020](#) standard requirements. Hydro One shall also specify the adequate level of basic insulation limits which shall then be used as a design guideline for the new Interconnecting Facility.

HYDRO ONE TRANSMISSION GENERATION INTERCONNECTION REQUIREMENTS

4.4 CONTINGENCY AND REMEDIAL ACTION SCHEME (RAS) REQUIREMENTS

The Interconnecting Facility is responsible for adequately designing and protecting its generating plant against transmission system changes due to switching operations, contingencies and equipment failure. Examples of system events are described below:

- Load rejections: may cause rotor acceleration and overvoltage at the synchronous generator.
 - Self-excitation: islanded systems or unloaded, long transmission lines may pose a capacitive load to the synchronous units and lead to self-excitation. This can lead to self-excitation and exposure to high voltages, which can cause equipment damage.
 - Resonance or near resonance: introduction of either series or shunt resonant conditions may lead to torsional interactions or high transient over-voltages.
 - Fatigue-life consumption due to fast reclosures: reclosing operations may impose significant transient electrical torque duties on generator shafts. Hydro One requires that the generating units are disconnected prior to energization of circuits to avoid unnecessary large transients on the units.
 - Loss of synchronism: generating units shall be equipped with out of step protection. System events, e.g., faults, may lead to generator acceleration and consequential loss of synchronism.
 - Remedial Action Schemes: The Interconnecting Facility may be required to participate in generation rejection, generation run back, in order to preserve the overall reliability of the transmission system. The System Operator will identify situations where these schemes are required and communicate those with the Generator Owner.
-

HYDRO ONE TRANSMISSION GENERATION INTERCONNECTION REQUIREMENTS

5 TESTING AND INSPECTION

The Customer shall demonstrate to Hydro One, through Confirmation of Verification Evidence Report (COVER), that the Interconnecting Facility will not have adverse impact on the operation of the Transmission System and nearby existing facilities. Once all that information is available, Hydro One will review it prior to issuing an authorization for energization of the Interconnecting Facility. Such tests and inspections will include pre-energization testing of equipment connected to the transmission bus, protection and control systems and pre-commercial testing of the governor, excitation and/or power system stabilizer controls. Protection and control systems include, but are not limited to, AC auxiliary, DC systems, relaying systems, potential and current circuits, and communication systems. Additionally, Hydro One shall test interfaces to ensure adequate communication facilities and devices are operating as expected.

The Interconnecting Facility shall be subjected to additional existing NERC, IESO and NPCC standards related to testing and inspection as needed.

HYDRO ONE TRANSMISSION GENERATION INTERCONNECTION REQUIREMENTS

6 DISTURBANCE MONITORING REQUIREMENTS

The primary objective of this requirement is to ensure that disturbance monitoring devices are installed to record system measurements during disturbances or events. The recorded data may be used for the reconstruction of events and to help understand the sequence of actions and their causes.

For each new generation Interconnecting Facility, IESO will identify Bulk Electric System buses and Bulk Power System elements. Event recording devices shall then be installed in accordance with [NERC PRC-002](#) and NPCC D11 regional reliability standards. IESO will identify DDR locations, while the Transmission Owner or Generator Owner will identify busses that require Sequence of Events recording (SER) and fault recording (FR) devices. Additionally, IESO may require the installation of phasor measurement units (PMUs) at critical locations for monitoring redundancy and higher visibility.

The Transmission Owner will notify the owner of the generation Interconnecting Facility as needed to inform them that they are connected to Transmission Owner BES busses that require SER/FR data. All data collection shall be performed in accordance with [PRC-002/ NPCC D11](#) requirements.

Installation, maintenance and collection of data from these devices shall be performed by the Interconnecting Facility for devices that are within its substations and are not physically accessible by Hydro One, or that are within the generation Interconnecting Facility. Upon request, power quality (PQ) data shall be collected and streamed to Hydro One using appropriate communication channels.

**HYDRO ONE TRANSMISSION GENERATION INTERCONNECTION
REQUIREMENTS**

APPENDIX A: LIST OF ACRONYMS

Acronym	Description
ANSI	American National Standards Institute
BES	Bulk Electric System
CIA	Customer Impact Assessment
CSA Group	Canadian Standards Association Group
EHV	Extra High Voltage
FERC	Federal Energy Regulatory Commission
HV	High Voltage
IBR	Inverter Based Resources
IESO	Independent Electricity System Operator
IEEE	Institute of Electrical and Electronics Engineers
kV	Kilovolt
MW	Megawatt
NERC	North American Electric Reliability Corporation
NPCC	Northeast Power Coordinating Council Inc.
OEB	Ontario Energy Board
ORTAC	Ontario Resource and Transmission Assessment Criteria
SIA	System Impact Assessment
SS	Switching Station
TS	Transformer Station
TSC	Transmission System Code

HYDRO ONE TRANSMISSION GENERATION INTERCONNECTION REQUIREMENTS

APPENDIX B: RELEVANT LINKS

ANSI

CSA Group

FERC

HYDRO ONE PROTECTION STANDARD

HYDRO ONE GENERATION CONNECTION PROCESS

HYDRO ONE COVER

IEEE

- IEEE C37.246 -2017, "[IEEE Guide for Protection Systems of Transmission-to-Generation Interconnection](#)".
 - IEEE 80-2000 – "[IEEE Guide for Safety in AC Substation Grounding](#)"
 - IEEE Std 421.1-2007, "[Standard Definitions for Excitation Systems for Synchronous Machines](#)"
 - IEEE Std 421.5-2016, "[IEEE Recommended Practice for Excitation System Models for Power System Stability Studies](#)"
 - IEEE 430-2017 – "[IEEE Standard Procedures for the Measurement of Radio Noise from Overhead Power Lines and Substations](#)"
 - IEEE Standard 519-1992, "[IEEE Recommended Practices and Requirements for Harmonic Control in Electrical Power Systems](#)".
 - IEEE Std 1453-2004, "[IEEE Recommended Practice for Measurement and Limits of Voltage Fluctuations and Associated Light Flicker on AC Power Systems](#)"
 - **IESO**
 - [Market Rules Chapter 4 Grid Connection Requirements](#)
 - [Market Rules Chapter 4 Grid Connection Requirements – Appendices](#)
 - **NERC**
 - FAC 001 [Facility Connection Requirements](#)
-

HYDRO ONE TRANSMISSION GENERATION INTERCONNECTION REQUIREMENTS

- FAC 002 [Facility Interconnection Studies](#)
- FAC 008 [Facility Ratings](#)
- MOD-025 [Verification and Data Reporting of Generator Real and Reactive Power Capability and Synchronous Condenser Reactive Power Capability](#)
- MOD-026 [Verification of Models and Data for Generator Excitation Control System or Plant Volt/Var Control Functions](#)
- MOD-027 [Verification of Models and Data for Turbine/Governor and Load Control or Active Power/Frequency Control Functions](#)
- PRC-001 [System Protection Coordination](#)
- PRC-002 [Disturbance Monitoring and Reporting Requirements](#)
- PRC-024 [Generator Frequency and Voltage Protective Relay Settings](#)
- TPL-001 [Transmission System Planning Performance Requirements](#)
- VAR-001 [Voltage and Reactive Control](#)
- VAR-002 [Generator Operation for Maintaining Network Voltage Schedules](#)

NPCC

- Directory 11 [Disturbance Monitoring Equipment Criteria](#)

OEB

TSC
