

---

Supersede: PP-60000-003-R0

# ***Protection Planning Standard for Transmission Generation Connections***

## **ASSET MANAGEMENT TRANSMISSION STANDARD**

© COPYRIGHT HYDRO ONE NETWORKS INC. ALL RIGHTS RESERVED

*This standard contains confidential and proprietary information and may not be reproduced or copied, in whole or in part, in any printed, mechanical, electronic film, or other distribution and storage without written permission from Hydro One Networks Inc. Recipients shall take reasonable steps to maintain in confidence the information contained in this standard.*

***Information Type: Intellectual Property - Refer to Policy SP1139***

---

**LIMITATION OF LIABILITY AND DISCLAIMER**

*Neither Hydro One Networks Inc. nor any person employed on its behalf makes any representations or warranties, expressed or implied, or assumes any liability for the accuracy, adequacy, or completeness of the information or data contained in this standard and does not accept any liability for the use or reliance on this standard or on any of the information or data contained herein under any circumstances whatsoever.*

**CONTACT/PUBLISHER**

*This standard is the responsibility of the Corporate Standards Division, Hydro One Networks Inc. Please contact the Manager and/or one of the Senior Standards Engineers with any queries or suggestions.*

*Hydro One Networks Inc.  
Corporate Standards Division  
483 Bay Street (TCT-13)  
Toronto, Ontario, M5G-2P5  
[www.HydroOne.com](http://www.HydroOne.com)  
email: [txgen.connect@HydroOne.com](mailto:txgen.connect@HydroOne.com)*

**REVISION HISTORY**

Date	Version	Revision Comments
October 2015	R0	Developed to incorporate updated connection requirements. Sections include: telecommunications; generator station protection; and connection issues.
September 2016	R1	Revised and edited for posting on web page

**TABLE OF CONTENTS**

**1.0 PROTECTION FUNCTIONAL REQUIREMENTS FOR TRANSMISSION CONNECTED GENERATION FACILITIES.....5**

1.1 ABBREVIATIONS AND DEFINITIONS .....6

1.2 TYPES OF CONNECTION.....8

1.3 PROTECTION REQUIREMENTS.....8

1.4 NPCC CRITERIA.....8

**2.0 GENERATION FACILITY CONNECTED TO HONI HV LINE TAP.....9**

2.1 HIGH VOLTAGE INTERRUPTING AND ISOLATING DEVICES .....11

2.2 GENERATOR HVI FAILURE PROTECTION.....11

2.3 HVI RECLOSING.....14

2.4 TRANSFER TRIP RECEIVED FROM HONI.....14

2.5 HV LINE PROTECTIONS.....14

2.6 BLOCKING SIGNALS TO HONI LINE PROTECTIONS .....16

2.7 UNGROUNDED UNIT TRANSFORMER.....20

**3.0 GENERATION FACILITY CONNECTED TO HONI LINE BY MEANS OF A GENERATION FACILITY TRANSMISSION LINE .....22**

3.1 HIGH VOLTAGE INTERRUPTING AND ISOLATING DEVICES .....23

3.2 HVI FAILURE PROTECTION .....23

3.3 HVI RECLOSING.....27

3.4 TRANSFER TRIP RECEIVED FROM HONI.....27

3.5 HV LINE PROTECTIONS.....28

3.6 BLOCKING SIGNALS TO HONI LINE PROTECTIONS .....30

**4.0 GENERATION FACILITY CONNECTED TO SECTIONALIZED HONI LINE .....31**

4.1 PROTECTION OF HONI LINE SECTIONS .....31

4.2 PROTECTION OF GENERATOR'S LINE.....31

4.3 BUS PROTECTION IN THE SECTIONALIZING SWITCHING STATION .....31

4.4 GENERATION FACILITY HVI BREAKER FAILURE PROTECTION .....32

**5.0 GENERATION FACILITY CONNECTED TO HONI HV STATION .....34**

**6.0 AUTOMATIC RECLOSING .....35**

**7.0 UNDER-FREQUENCY PROTECTION .....36**

**8.0 TELEPROTECTION.....37**

**9.0 COMMUNICATIONS WITH MULTI-TAPPED GENERATION FACILITIES.....38**

**10.0 GENERATION FACILITY STATION PROTECTIONS .....39**

10.1 COMMUNICATION MEDIA FOR NPCC IMPACTIVE FACILITIES .....39

10.2 GENERATION REJECTION OF WIND FARMS FROM A REMEDIAL ACTION SCHEME .....40

**11.0 GENERAL TELECOM REQUIREMENTS.....43**

**12.0 DISTURBANCE MONITORING .....43**

**13.0 DC STATION SERVICES .....44**

**14.0 REFERENCES.....44**

**TABLE OF FIGURES**

Figure 1 - Overview of Some of the Terminology Used in this Document ..... 7

Figure 2 - Generation Facility Tapped to Nearby HONI HV Line ..... 10

Figure 3 - Generator HVI Breaker Failure Protection ..... 12

Figure 4 - Breaker Failure Transfer Trip Signal Sent from HONI to Generator HVI (cascading option shown) ..... 13

Figure 5 - Generator Breaker Failure Protection ..... 13

Figure 6 - Tapped Generation Facility and Remote-End Fault with HONI Infeed ..... 15

Figure 7 - Tapped Generation Facility and Remote-End Fault with No HONI Infeed ..... 15

Figure 8 - Two Tapped Generation Facilities and Remote End Fault with No HONI Infeed ..... 16

Figure 9 - HONI Line Protection Looking into Generation Facility ..... 17

Figure 10 - Generation Facility Protections Used for HONI Line Blocking Signal ..... 19

Figure 11 - Blocking Signals Transmitted to HONI from Generation Facility Protections ..... 20

Figure 12 - Overvoltage/Undervoltage HV Line Ground Protection ..... 21

Figure 13 - Generation Facility Tapped to HONI HV Line via Facility Owned Transmission Line ..... 22

Figure 14 - Generation Facility Switching Station HVI Breaker Failure Protection ..... 24

Figure 15 - Breaker Failure Transfer Trip Signal Received from HONI ..... 25

Figure 16 - Generator HVI Breaker Failure Protection ..... 26

Figure 17 - Breaker Failure Protection for Generator Breaker ..... 27

Figure 18 - Route Diversification Required for Line Differential Protection ..... 29

Figure 19 - Route Diversification (Communication Only) ..... 29

Figure 20 - Blocking Signal to HONI Transmission Line Protections ..... 30

Figure 21 - Generation Facility Switching Station and HONI Switching Stations for a Sectionalized HV Line ..... 32

Figure 22 - Generation Facility HVI Failure Protection with Fault on Facility Line ..... 33

Figure 23 - Generation Facility HVI Failure Protection with Fault on HONI Bus ..... 33

Figure 24 - HONI Breaker Failure Protection for a Fault on the HONI Bus ..... 34

Figure 25 - Generation Facility Connected to HONI Station Diameter ..... 35

Figure 26 - Automatic Reclosing of Terminal Breakers ..... 36

Figure 27 - Generator Under Frequency Protection Requirements ..... 37

Figure 28 - Cascaded Generator Communications with HONI ..... 38

Figure 29 - Generation Facilities Tapped Directly to Transmission Line ..... 39

Figure 30 - Generation Facility Connection without Intermediate Voltage Level – Option 1 ..... 41

Figure 31 - Generation Facility Connection with Intermediate Voltage Level - Option 2 ..... 42

Figure 32 - Generation Facility Connection with Intermediate Voltage Level - Option 3 ..... 42

---

## 1.0 PROTECTION FUNCTIONAL REQUIREMENTS FOR TRANSMISSION CONNECTED GENERATION FACILITIES

This document provides a guide to HONI's protection requirements for transmission connected generation.

The Ontario Energy Board's Transmission System Code (TSC) establishes the minimum standards for facilities connected to a transmission system. Within the TSC, Schedule E in Appendix 1B identifies the general technical requirements for protection and control, while Schedule F identifies the additional technical requirements specific to the connection of generation facilities to the transmission system.

In addition, the *Market Rules* created and enforced by the Independent Electricity System Operator (IESO), which governs electricity market operations, oversees the electricity wholesale market in Ontario, balances the supply of and demand for electricity, and directs the operation of the transmission system ensuring reliable electricity supply. To participate in Ontario's electricity wholesale market, participants shall ensure that their equipment and facilities connected to the IESO-controlled grid adhere to the reliability standards and grid connection requirements identified in the IESO's *Market Rules*.

Chapter 4 (Grid Connection Requirements) of the Market Rules sets the IESO mandated connection rules and obligates market participants to adhere to the transmitter's design criteria. Chapter 5 (Power System Reliability) mandates additional compliance with all reliability standards, should they be applicable, by the defined standards authorities (i.e. NERC and NPCC).

The North American Electric Reliability Corporation (NERC) is an international organization whose mission is to assure the reliability of the bulk power system in North America. It consists of seven regions where the area of responsibility spans the continental United States, Canada, and the northern portion of Baja California, Mexico. In the United States NERC is subject to oversight by the Federal Energy Regulatory Commission (FERC). In Canada, NERC is subject to provincial authorities (i.e. OEB). NERC monitors the system reliability and performance and educates trains and certifies operating personnel. In addition to this, NERC has developed a set of mandatory Reliability Standards. NERC's protection reliability standards with prefix "PRC" are available on their web site.

Ontario is covered by the Northeast Power Coordinating Council (NPCC). The Northeast Power Coordinating Council is one of the seven regions under NERC. Its mission is to promote and improve the reliability of the interconnected bulk power system in northeastern North America. NPCC carries out its mission through the development and enforcement of region-specific reliability standards and criteria which address region-specific reliability requirements. Beside other regulations, NPCC's Directory #4 and Directory #7 specifically deal with protection and control for the participating facilities /Ref. 1,2/

Compliance with Market Rules is mandatory, as well as with NERC and NPCC standards that may be applicable. Memorandum of understanding signed between the OEB, NERC and NPCC

specified that the roles of compliance oversight and enforcement in Ontario are fulfilled by the IESO’s Market Assessment and Compliance Division (MACD). In addition, HONI is obligated to review the design of transmission and generation segments connected to the HONI transmission system and the impact of those connected transmission and generation segments on the HONI transmission system.

The Protection Impact Assessment (PIA) prepared by HONI forms a part of IESO’s System Impact Assessment (SIA). The System Impact Assessment document establishes whether the proposed connection can be adequately protected and does not degrade the protection reliability for existing transmission facilities in the area. The PIA establishes HONI’s minimum requirements for the protection scheme and telecom infrastructure. Should the proposed connection be found not feasible to protect the reliability of the existing system, the connection may be denied.

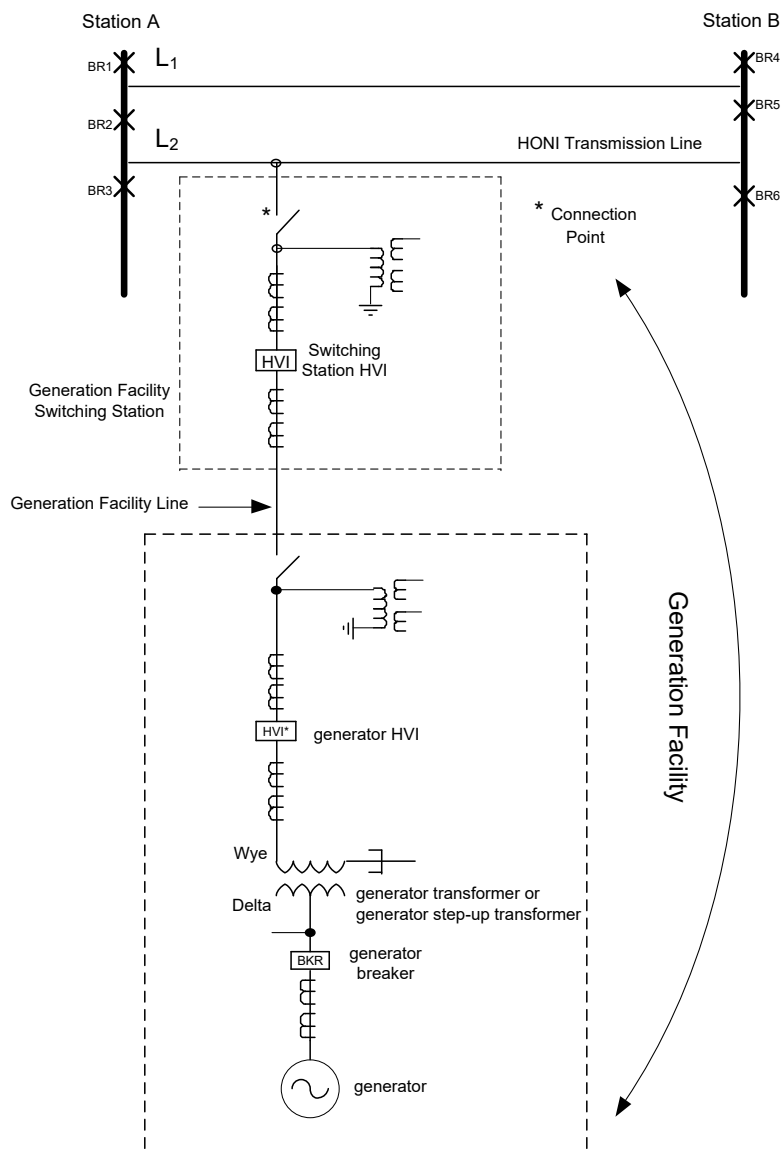
This present document (Protection Planning Standard for Transmission Generation Connections) is intended to provide further clarification of these requirements.

### 1.1 ABBREVIATIONS AND DEFINITIONS

The following is a list of abbreviations and definitions used in this document.

Connection Point.....	The point at which the Generation Facility connects to the HONI system - typically at the jaw of the disconnect switch. Also referred to as “HONI Tap” and “Point of Interconnection”
Generation Facility.....	The connected equipment including the physical generator up to the Connection Point.
Generation Facility Owner.....	The owner of the actual physical generator and everything up to the Connection Point.
Generation Facility Line.....	The line connecting the high voltage of the generator step-up transformer to the Connection Point or to the Generation Facility Switching Station.
Generation Facility Switching Station	Switching Station belonging to Generation Facility Owner.
GEO.....	Generation End Open
HONI Tap.....	Same as Connection Point
HV.....	High Voltage transmission voltages from 115 kV to 500 kV
HVI.....	High Voltage Interrupting device. This could be one of: Circuit Breaker; Circuit Switcher; or Vacuum Interrupter
MV.....	Medium Voltage levels between HV and LV
LV.....	Low Voltage (generator output) voltage level
NERC.....	National Electricity Reliability Council
NPCC.....	Northeast Power Coordinating Council
RAS.....	Remedial Action Scheme
SPS.....	Special Protection Scheme
Switching Station HVI.....	The HVI at the Generation Facility Switching Station
TRV.....	Transient Recovery Voltage

Figure 1 illustrates a number of the terms listed above.



**Figure 1 - Overview of Some of the Terminology Used in this Document**

Throughout this document the terms “Facility Owner”, “Facility Line”, “Facility Switching Station” etc. all refer to the generation connection – that is, “Facility Owner” is the equivalent to “Generation Facility Owner” etc. “Switching Station HVI” and “generator HVI” both refer to the Generation Facility. A “generator” refers to the actual physical generator at the Generation Facility. Reference to the “Connection Point” and the “HONI tap” are equivalent. Also, the terms “transmission line” and “line” are equivalent.

---

## 1.2 TYPES OF CONNECTION

Generation Facilities may be connected to the HONI transmission system in several ways, such as: tapping directly to a transmission line, connecting into a HONI Switching station diameter or connecting to the low voltage bus of a transmission Load Connection station. Generation Facilities may also be connected to a radial line. Multi-tap generation is the term used to describe the situation where multiple sources of generation are tapped directly to the same transmission line.

## 1.3 PROTECTION REQUIREMENTS

The requirements listed in this document shall apply to new Generation Facility connections in addition to the provisions stipulated under Schedule F of the TSC. Additional protection requirements may also be stated in the PIA performed by HONI.

The following obligations on the Generation Facility Owner are required by HONI:

- Specific (detailed) requirements for connection protection shall be discussed with HONI during the design preparation stage prior to any work being commenced.
- Review and acceptance of Generation Facility Owner's design, construction, maintenance procedures, etc., by HONI is mandatory.
- Neither HONI nor the Generation Facility Owner shall rely on the other's protection scheme to protect their own equipment.
- HONI utilizes three-pole tripping exclusively and no exceptions will be made to this philosophy.
- Generation Facility Owner's equipment, such as line protections, communications equipment, or transfer trip relaying must be compatible with HONI-owned equipment where applicable. Examples of such equipment include: line differential schemes plus communication schemes and protocols used for teleprotection.

## 1.4 NPCC CRITERIA

The Generation Facility Owner must, at the outset, confirm with the IESO whether their proposed Generation Facility connection to HONI is NPCC impactive. This classification will have an influence on the communication and protection schemes being used and must be determined before the protections are designed. The Generation Facility's NPCC classification must be clearly identified in the application form that is submitted to HONI. This information is an essential component in HONI's Customer Impact Assessment (CIA) and Protection Impact Assessment (PIA). Irrespective of voltage level this classification will also influence the level of redundancy required by the Generation Facility Owner for the Generation Facility's protections.

When classified as NPCC impactive, the Generation Facility Owner must design their protection and communication schemes according to NPCC Directory #4. NPCC Directory #4 requires that the Generation Facility Owner submit their protection and communication scheme designs to the NPCC Task Force in System Protection (TFSP) for review and approval.



---

Should at least one of HONI's stations involved be on the Bulk Power System (BPS) list, which is a list of NPCC impactive facilities produced by the IESO, even though a customer's facility is not classified as NPCC impactive, certain protection schemes may be required to be designed according to NPCC Directory 4 criteria. The BPS list is a list of NPCC impactive facilities produced by the IESO. The impacted schemes can be line protection and teleprotection channels, as well as other protections, depending on the customer's station configuration.

In addition, when per IESO's System Impact Assessment (SIA), the Generation Facility Owner is required to participate in generation rejection as part of a Remedial Action Scheme (RAS)<sup>1</sup> which has been (or will be) classified by NPCC as Type 1, Directory #7 will apply even though the facility may not be classified as BPS under NPCC.

Classification as part of a RAS scheme may require the use of specific design criteria such as high speed communications, dual batteries and or dual trip coils to mention only a few. For example, if included in a Remedial Action Scheme, the Generation Facility Owner must provide separate telecom circuits to provision the generation rejection signals. Further information can be found in NPCC Directory #7 for Type 1 RAS schemes.

It is prudent for the Generation Facility Owner to consider adhering to the criteria in NPCC Directory #4, even though the Generation Facility is not deemed to be NPCC impactive at the time of connection. The IESO may be consulted to determine the possibility of the Generation Facility being deemed to be NPCC impactive in the future.

The labelling convention used in the following figures identifies the HONI station on the left as "Station A" and the HONI station on the right as "Station B". Each HONI-owned station (Station A and Station B) have duplicate protections which are also labeled A and B. Thus HONI Station A has one "A" and one "B" protection and HONI Station B has one "A" and one "B" protection. The A and B labeling of the stations was maintained in order to be consistent with the Figures given in the TSC.

Although synchronous generators are used in the examples throughout this document, the requirements for Generation Facility connections to the transmission system apply equally to both synchronous and non-synchronous generation.

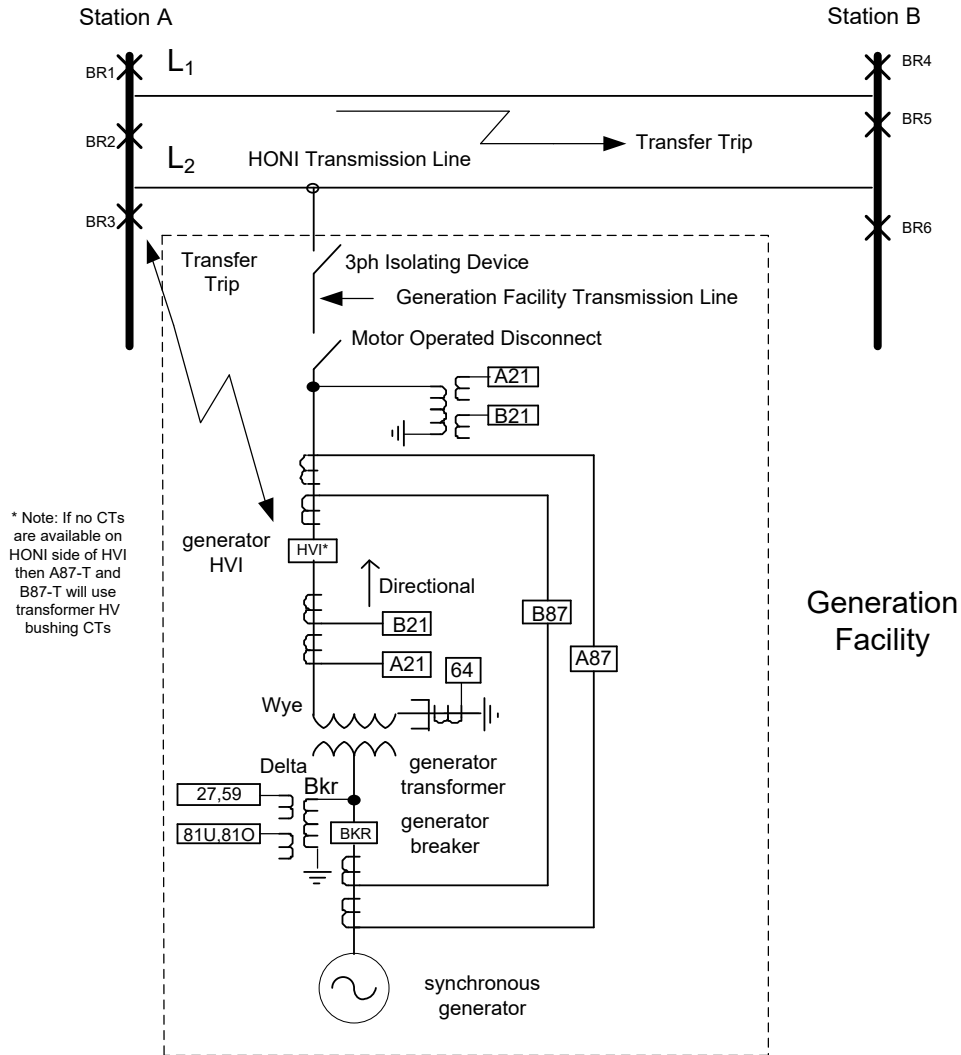
## 2.0 GENERATION FACILITY CONNECTED TO HONI HV LINE TAP

The distance from the HONI tap to the generator will be deemed close to the HONI tap (and refer to this Section, Section 2.0) or "at the end of a Generation Facility Line" (Section 3.0) during the initial connection assessment. This differentiation between Section 2.0 and Section 3.0 will depend on the distance between the tap and the generator as well as possible other factors such as terrain, grounding requirements, size (MW) of the generator and fault contribution.

---

<sup>1</sup> Formerly Special Protection Scheme (SPS)

Figure 2 below shows the protections for a Generation Facility tapped to a HONI line near-by the right-of-way. The three-phase isolating device is owned by the Generation Facility Owner and provides a point of isolation as per the TSC<sup>2</sup>.



**Figure 2 - Generation Facility Tapped to Nearby HONI HV Line**

<sup>2</sup> “The Customer shall provide an isolating disconnect switch or device at the point or junction between the Transmitter and the Customer, i.e., at the point of the interconnection, which physically and visually opens the main current-carrying path and isolates the Customer’s facility from the transmission system.” — excerpt from section 1.2.1 in Schedule E of the TSC. By Order of the OEB in the EB-2015-0262 proceeding, HONI is exempt from section 1.2.1 of Schedule E of Appendix 1 of the Transmission System Code. HONI is developing a corporate policy in this area.

When the Generation Facility is connected to a HONI line where either Station A or Station B (see Figure 2 above) is deemed NPCC impactive (as determined by the IESO), the Generation Facility's HV switchgear, bus and transformer may also be deemed NPCC impactive.

## 2.1 HIGH VOLTAGE INTERRUPTING AND ISOLATING DEVICES

A three phase High Voltage Interrupting device (HVI) along with a motor operated disconnect switch is the point of isolation for the Generation Facility from the HONI system. The HVI may be a circuit breaker (preferred) or other similar device such as a circuit switcher dependent on HONI's authorization. The actual demarcation point between HONI and the Generation Facility is the jaw of the isolating switch/link. This switch/link is owned and maintained by the Generation Facility Owner. Some performance requirements for HVIs are given in the TSC; however, additional requirements may be necessary in some cases as determined by IESO's or HONI's studies (e.g. increased TRV values etc.).

The three-phase disconnect switch/isolating device is required at the Connection Point as a visual indicator confirming isolation of the Generation Facility from the HONI network for safety purposes. The three-phase isolating device must be visible from outside of the Generation Facility fence or property line.

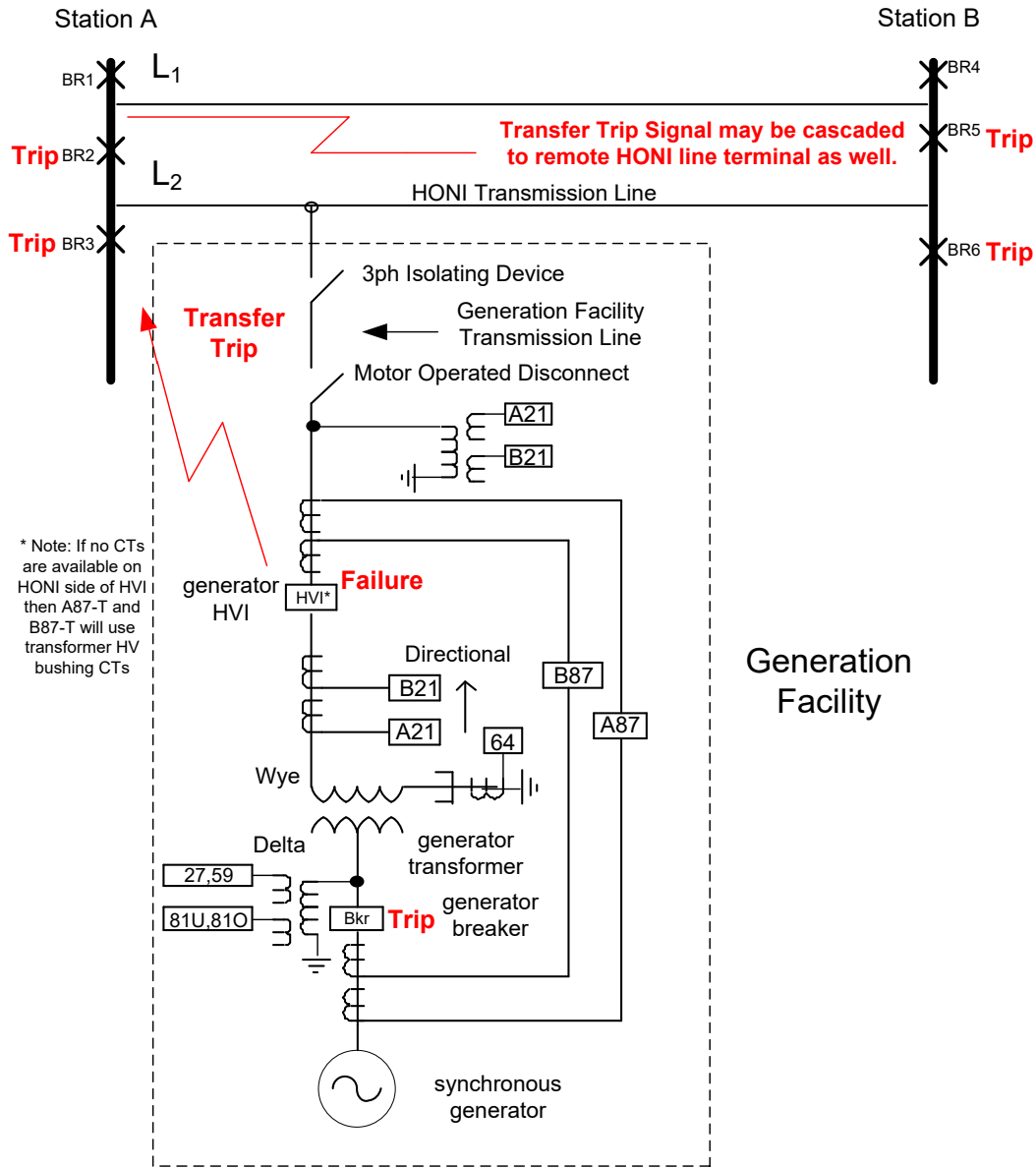
## 2.2 GENERATOR HVI FAILURE PROTECTION

The generator HVI requires breaker failure protection. This protection is necessary should the HVI fail to open while required to do so from either the Generation Facility protections or from transfer trip signals received from remote terminals. The generator HVI breaker failure protection simultaneously trips the adjacent local generator breaker and sends a transfer trip signal to HONI to trip its line terminal stations breakers as shown in Figure 3.

The following is a list of requirements for Generation Facility breaker failure protections:

- The breaker failure protection need not be duplicated and preferably should be supplied from the "A" battery supply.
- The breaker failure protection should recognize mechanical failure of the HVI or the inability of the HVI to extinguish an arc under fault conditions.
- The breaker failure protection signal must:
  - Seal-in for 45 seconds to ensure reclosing does not occur from HONI breakers.
  - Be supervised by the status of the motorized disconnect switch.

The HONI breakers at the terminal stations also have breaker failure protection. Any one of these breakers could fail for a fault outside of the Generation Facility. When these breaker failure protections operate, they will send a transfer trip signal to the generator HVI that interfaces with the generator. Figure 4 below depicts this scenario. HONI initiated breaker failure trip signals are always sealed-in at the sending end for 45 seconds. The Generation Facility Owner may find the 45 second seal-in time useful for discriminating between various transfer trip signals.



**Figure 3 - Generator HVI Breaker Failure Protection (Cascading Option Shown)**

The generator breaker must also be provided with breaker failure protection. The generator breaker failure protection simultaneously trips the generator HVI or other local adjacent breakers and shuts down the generator by tripping its field breaker (in the case of a synchronous generator) and by removing its prime mover as shown in Figure 5 below. This breaker failure protection is required to prevent HONI from feeding into an uncleared fault in the Generation Facility zone with the generator breaker having failed.



### 2.3 HVI RECLOSING

Automatic reclosing by the Generation Facility is not permitted as HONI must control reclosing and energization of the line. HONI utilizes a single shot automatic reclosing attempt for transmission line tripping with no prior initiation to the Generation Facility provided.

### 2.4 TRANSFER TRIP RECEIVED FROM HONI

When HONI line protections operate, they must isolate the entire line zone to eliminate all in-feeds to a line fault. In order to achieve this HONI sends a transfer trip signal to the Generation Facility. The transfer trip signal when received by the Generation Facility trips the interfacing HVI and initiates its breaker failure protection.

The Generation Facility will receive transfer trip signals sent from the HONI A and B line protections. "A" and "B" transfer trip communication channels transmitted over Main and Alternate communication routes are required which in many cases need to be diversely routed and not subject to single point of failure. NOTE: Leased circuits alone generally do not meet the necessary diversity requirements. Where the Generation Facility is deemed not to be NPCC impactful for uncleared HV faults, a single route for the two transfer trip signals may be sufficient between the Generation Facility and the HONI line protections. However, this is to be determined by HONI on a case-by-case basis during the preparation of the PIA.

### 2.5 HV LINE PROTECTIONS

A dedicated HV line protection is required at the Generation Facility to trip its interfacing HVI for phase and ground faults on the HONI-owned HV transmission line<sup>3</sup>. The Generation Facility's line protection will be definite time delayed to coordinate with HONI line protections in adjacent zones. The Generation Facility's line protection must be capable of seeing all phase and ground faults on the HV transmission line at inception of the fault and/or following the operation of the HONI line protections. That is, when HONI protections have cleared a transmission line fault from its remote terminal breakers, the Generation Facility's line protection must be able to detect the same fault and trip the Generation Facility from the line accordingly thereby severing its connection from the HONI transmission network. It is understood by HONI that it is not always possible to set the Generation Facility's line protection to cover all in-zone remote line faults while the HONI system is simultaneously feeding into the fault. The HONI current infeed to the fault would typically be significantly higher than the infeed from the Generation Facility, thereby creating comparatively large apparent impedance seen from the Generation Facility looking into the line.

Figure 6 below shows a tapped Generation Facility with a remote-end fault on the HONI transmission line. Prior to the HONI line protections tripping the terminal station breakers, current infeed to the fault is shared between the HONI network and the Generation Facility. The apparent impedance seen by the line protection at the Generation Facility can be excessively high. Should this be the case, the Generation Facility's line protections need not be set to cover this scenario and sequential tripping is accepted.

<sup>3</sup> "Dedicated" implies that the HV line protection function is not simply a part of the generator relay but is, in fact, a totally ("dedicated") device.

The intent of the Generation Facility Owner’s protection design and settings is to clear the faults independently in the shortest possible time. Depending on the apparent impedance and the fault location, it may be possible that a Transfer Trip (TT) received from HONI’s terminal stations will clear the faults faster than the Generation Facility’s own protection. The Generation Facility’s line protection settings must be reviewed by HONI for coordination and by the IESO for system impact assessment.

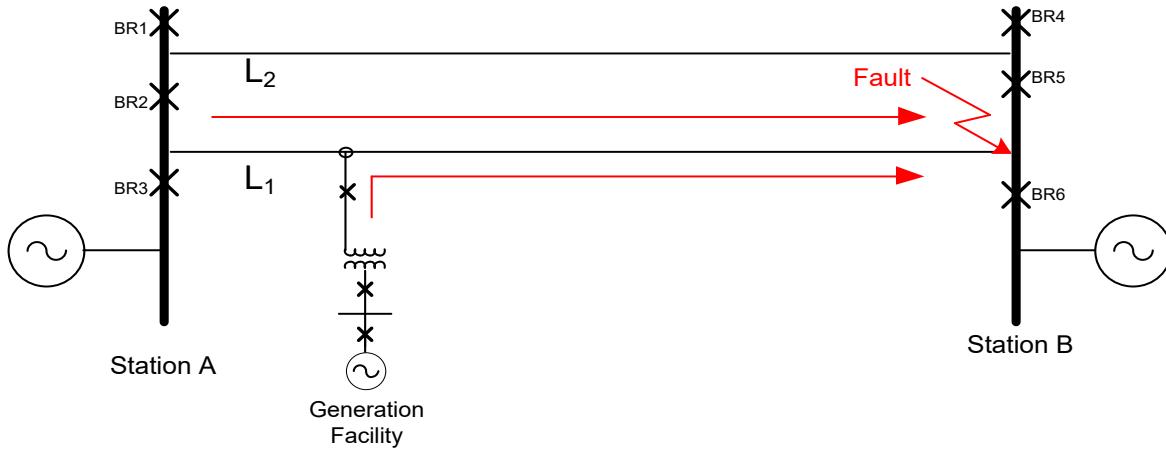


Figure 6 - Tapped Generation Facility and Remote-End Fault with HONI Infeed

Figure 7 below shows a tapped Generation Facility with the same remote-end fault on the HONI transmission line. Following the successful tripping of the terminal station breakers by HONI’s line protections, the only infeed to the fault is via the Generation Facility. In this case, there is no apparent impedance to be concerned about as the HV line protection impedance at the Generation Facility needs to be calculated based on the furthest remote-end fault location.

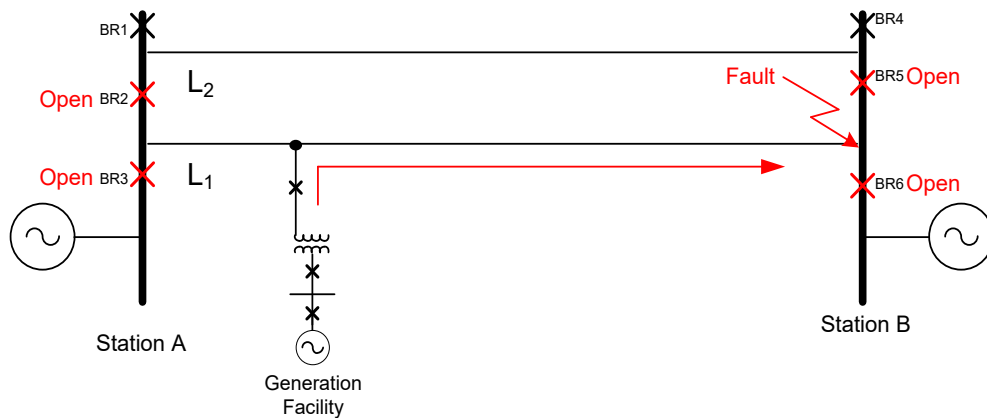


Figure 7 - Tapped Generation Facility and Remote-End Fault with No HONI Infeed

Figure 8 below shows two independent tapped Generation Facilities with the same remote-end fault on the HONI transmission line. The HONI HV line protections send transfer trip to both

Generation Facility 1 and Generation Facility 2. A common mode transfer trip failure may occur in the telecom path. In this case, in order to correctly back-up a possible common mode transfer trip failure, the line protections at each Generation Facility must be set to cover the apparent impedance to a remote-end line fault with both Generation Facility 1 and Generation Facility 2 supplying infeed to the fault. Should the setting required be too high for practical use, the setting can be reduced and diversification of telecom channels will become a mandatory requirement regardless of being NPCC impactive or not.

In the case of at least one of the Generation Facilities being non-synchronous, variable capacity wind or solar type, the path diversification will be required regardless of the settings and regardless of being NPCC impactive or not (variable capacity Generation Facilities may not provide enough current infeed to the fault for them to actually detect a fault). Path diversification is a requirement but will be reviewed by HONI at the planning stage.

For a weak source, it may be necessary to use a voltage-based line protection since the apparent impedance may be too high.

The Generation Facility's HV line protection must not initiate a transfer trip to HONI terminal station.

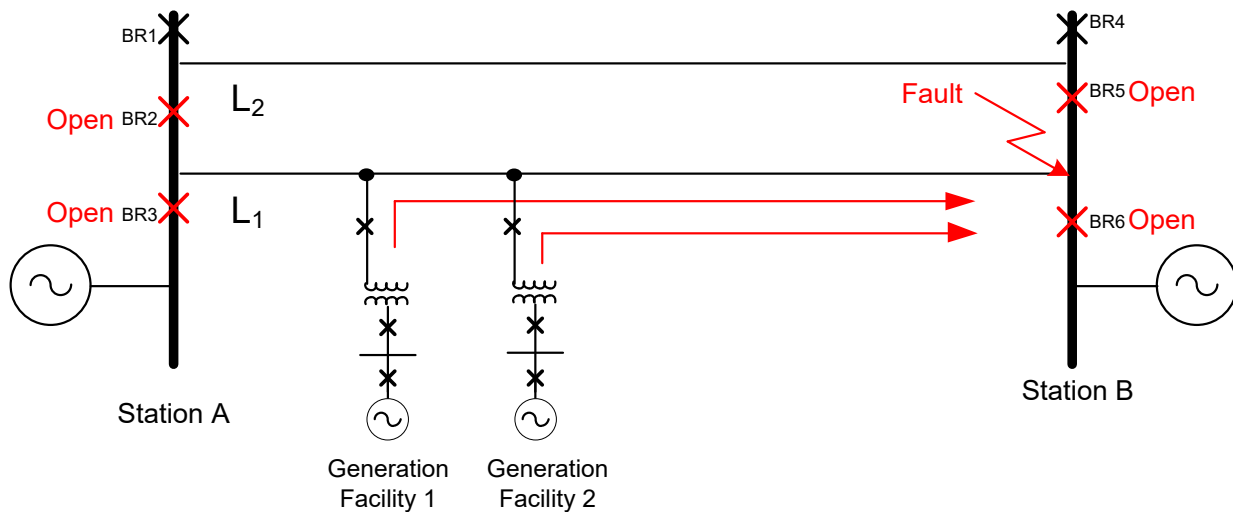


Figure 8 - Two Tapped Generation Facilities and Remote End Fault with No HONI Infeed

## 2.6 BLOCKING SIGNALS TO HONI LINE PROTECTIONS

Figure 9 below shows a typical HONI line protection set to normally cover the line and reach into the LV of a tapped generator transformer. In order to prevent over-tripping the HONI line protection should not trip the line for faults anywhere within the LV zone of the Generation Facility. This includes faults within the generator transformer, generator, or the interconnecting bus work and switchgear between the generator and the generator transformer.



HONI will determine by means of calculation whether there is an overreaching issue or not. This will be dependent on factors such as the proximity of the Generation Facility to the HONI line terminals in addition to the Generation Facility's line and transformer impedances.

For those cases where overreaching is confirmed to be an issue, the acceptable solution is for the Generation Facility protections to send a blocking signal back to the HONI line protections. HONI's line protections are typically time delayed to allow for the blocking signal to arrive from the Generation Facility protections before tripping its breakers at the terminal stations. This time delay in the HONI line protection is dependent on the communication medium being used and breaker clearing times. Delays are set to ensure that high speed tripping occurs as per HONI standards.

A time delayed line protection, as described above, is a Directional Comparison Blocking (DCB) pilot scheme. When the existing pilot scheme is not DCB, conversion to DCB proposed by HONI must be approved by IESO. Should DCB be prohibited, other solutions to avoid tripping on LV overreach must be found or the connection may be denied.

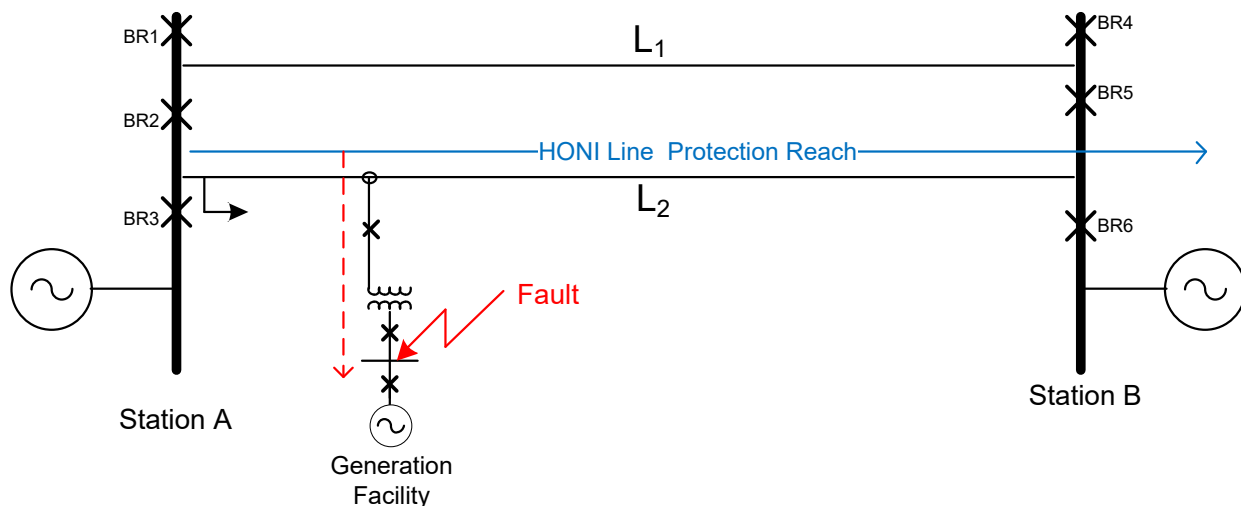


Figure 9 - HONI Line Protection Looking into Generation Facility

The blocking signal shall come from a reverse looking distance zone of Generation Facility's line protection. In some rather rare cases, when approved by HONI, other sources of blocking signals may be utilized. Figure 10 shows transformer and generator differential protections at the Generation Facility. Both the transformer and generator are protected with A and B differential protections. These protections overlap around the generator breaker. Any phase fault, whether in the transformer or generator, is seen by at least the transformer or generator or both differential protections. Both of these protections may sometimes effectively be used to initiate the transmission of a block signal to HONI line protections. This approach may not be acceptable for sending blocking signals back to BPS stations as additional NPCC Directory #4 require-

---

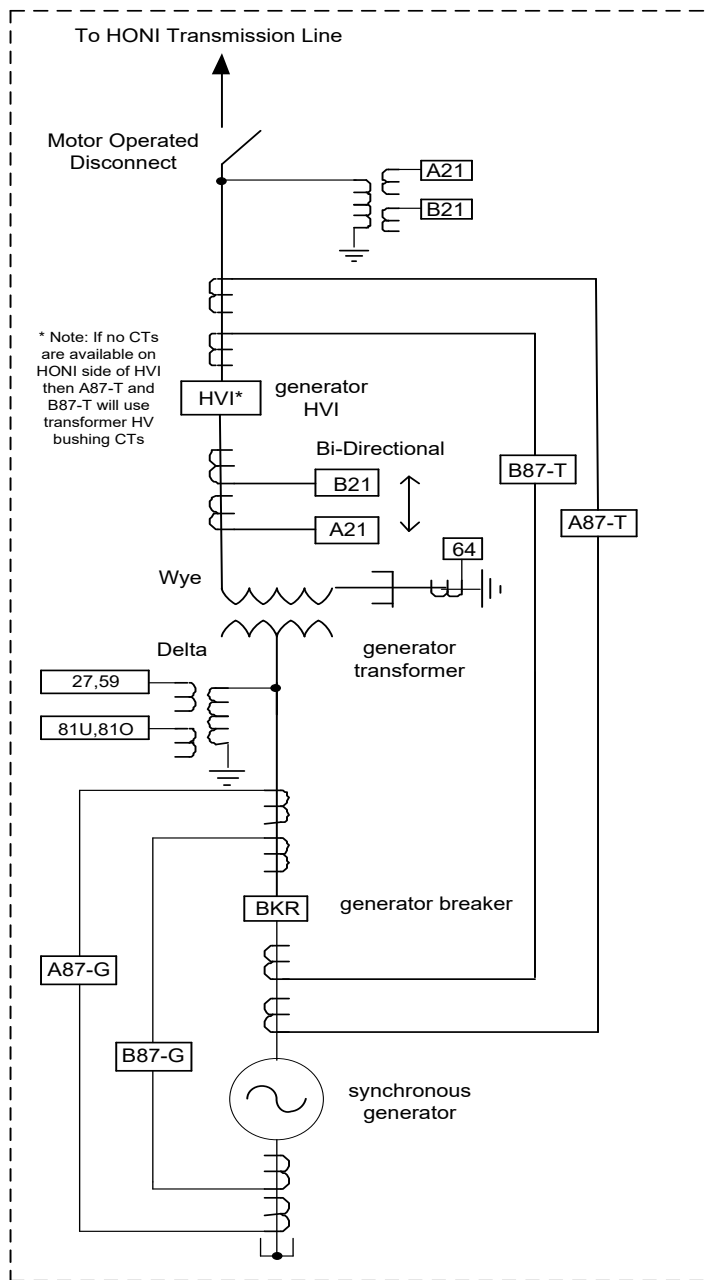
ments may apply to the Generation Facility's protections as well as other Generation Facilities with more complex configurations.

The transformer differential protections of the Generation Facility will send a blocking signal to the HONI line protections for transformer faults.

The HV A and B line distance (both ground and phase) protections at the Generation Facility can be set to be bi-directional with independent elements and settings. It is preferred to use the elements directioned toward the generator to send blocking signals to HONI line protections to block for both phase and ground faults provided the phase distance and ground distance protection elements are invoked. When these distance elements are used for blocking signals neither the transformer differential nor generator differential protections need send blocking signals as all phase and ground faults possibly seen by HONI line protections are also seen by these protections. The choice of whether to use the distance protections or the differential protections to send blocking signals is left to the discretion of HONI.

Two blocking signals are required, one from each of the "A" and "B" protections at the Generation Facility. The "A" line protection at the Generation Facility sends a blocking signal to the HONI "A" protection and the "B" line protection at the Generation Facility sends a blocking signal to the HONI "B" protection. It is necessary for the blocking signals to be transmitted via Main and Alternate communication routes because in this manner the loss of a single communication channel will not leave the circuit exposed to over tripping. Overtripping is usually prevented, for example, by operational circumvention by means of blocking all "A" protections should one "A" protection be removed from service for maintenance procedures.

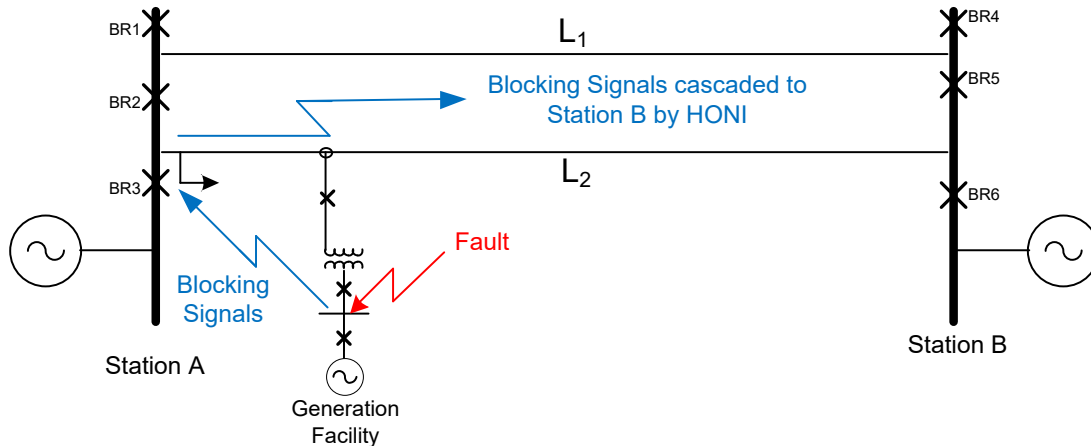
[Figure 10 Follows]



**Figure 10 - Generation Facility Protections Used for HONI Line Blocking Signal**

Figure 11 below shows blocking signals transmitted to HONI line protections to prevent them from over tripping for faults within the Generation Facility. The blocking signals need to be transmitted to both line terminals. In some cases, as determined by HONI, the A and B blocking signals can be sent to a single HONI line terminal for cascading to the remote line terminal via HONI internal teleprotection facilities as part of the overall HONI line protections.

It shall be assumed that blocking signals are to be sent to both Station A and Station B in which case both Stations will wait a predetermined amount of time for the blocking signal to arrive. However, if blocking signals are approved to be sent only to one station (Station A in this case) then an additional delay will be added at Station B as it waits for the cascaded blocking signal to arrive from Station A. This may not be acceptable due to system stability issues or diversification requirements. Time delays in the HONI line protection are dependent on the communication medium being used and breaker clearing times. Delays are set to ensure that high-speed tripping occurs as per HONI standards.



**Figure 11 - Blocking Signals Transmitted to HONI from Generation Facility Protections**

## 2.7 UNGROUNDED UNIT TRANSFORMER

The HONI transmission system is an effectively grounded system and the normally required unit transformer configuration is wye-gnd on the HV line side. However, the Transmission System Code (TSC) does allow for the Generation Facility Owner to configure its unit transformer as an ungrounded wye upon permission of HONI or this configuration may in fact be requested by HONI. From a protection perspective the ungrounded transformer is no longer a ground source for ground faults on the HV line. The Generation Facility ground distance relays directioned into the HV line would not be capable of detecting ground faults on the line after the line is tripped by the HONI terminal breakers.

Three phase voltages are measured on the HV line side of the generator transformer in order to detect ground faults on the line when the transformer is not a source of ground. These three HV side Voltage Transformers (VTs) are connected in a wye-grounded configuration for primary and secondary windings. An open corner delta configuration for the secondary winding is not recommended as a secondary circuit failures can't be effectively detected during normal operating conditions. Modern relays generally use all three voltage phases of the secondary to detect a ground fault by measuring secondary generated zero sequence voltage whenever a ground fault occurs on the HV line. Figure 12 shows an HV ungrounded-wye configured unit transformer with both overvoltage and undervoltage HV line ground protection.

The application of overvoltage and undervoltage measuring relays to detect ground faults is only effective when all other sources of ground current (zero sequence current) have been eliminated by the tripping of breakers. When this is the only Generation Facility connected to the HV line that would be the case as HONI will have tripped its breakers at the terminal stations prior to needing this protection to operate. However, when there is more than one Generation Facility connected to the HV line and their generator unit transformers are configured as wye-ground on the HV side, they provide a source of ground current to flow. The flow of ground current to the fault from these other sources sharply reduces the ability to set the overvoltage and undervoltage protections effectively at the Generation Facility.

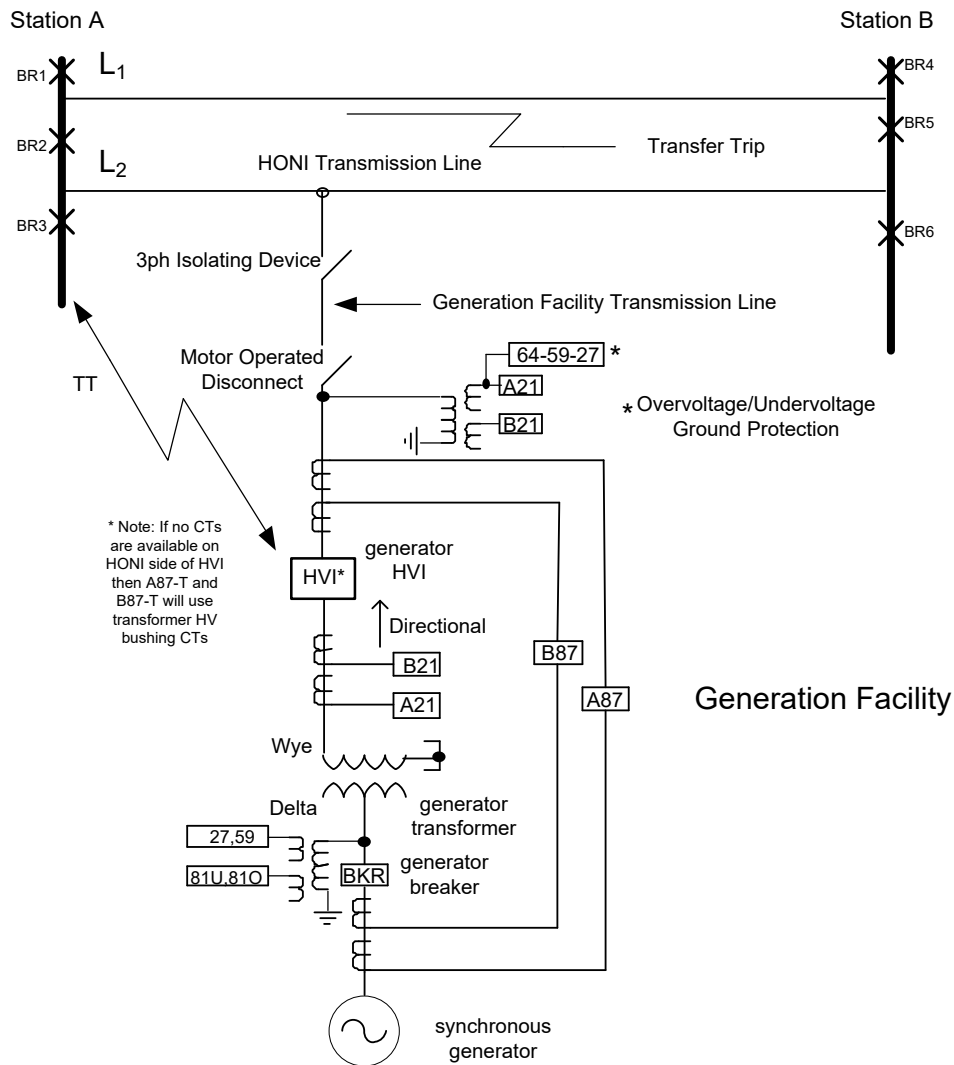
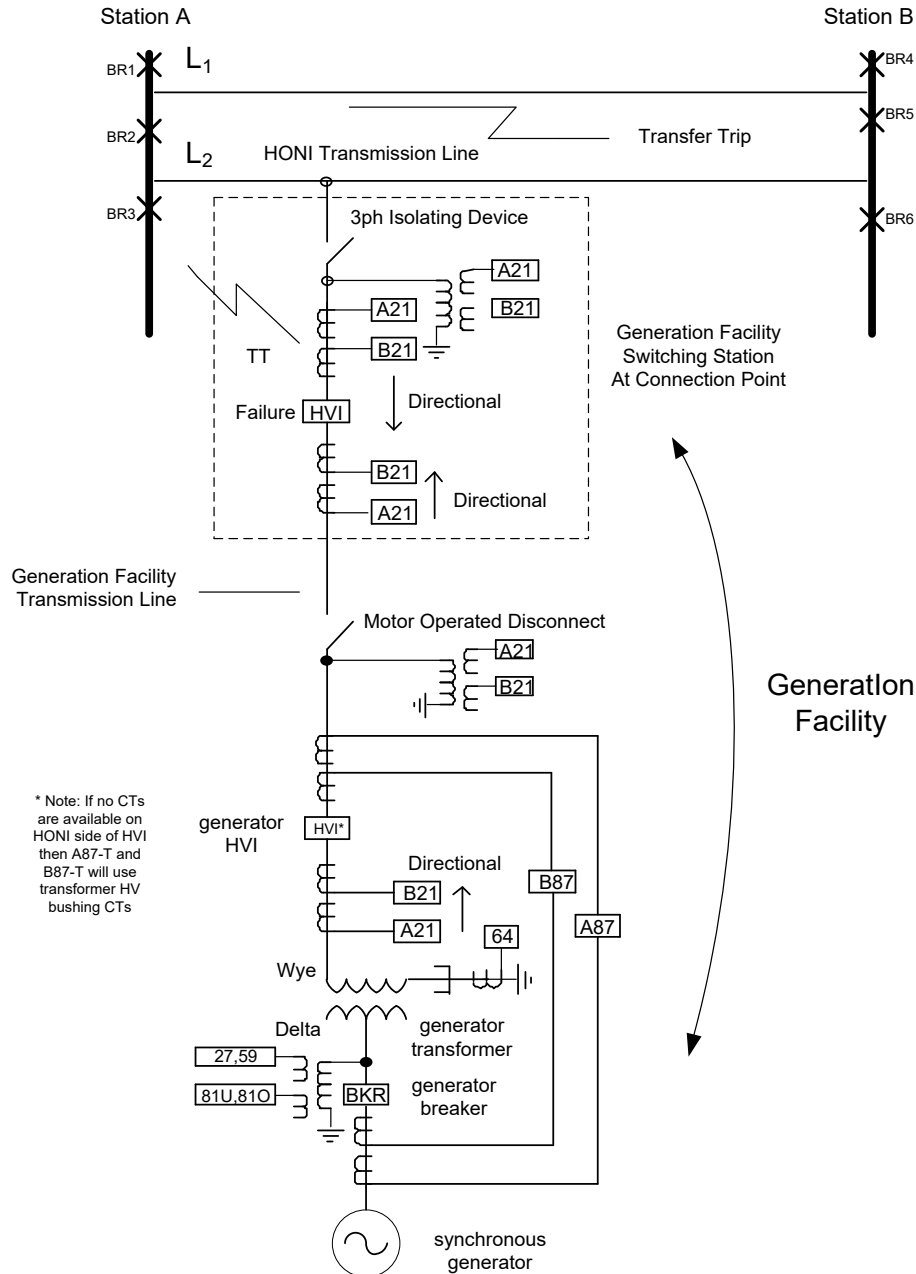


Figure 12 - Overvoltage/Undervoltage HV Line Ground Protection

### 3.0 GENERATION FACILITY CONNECTED TO HONI LINE BY MEANS OF A GENERATION FACILITY TRANSMISSION LINE

Figure 13 below shows the protections for a Generation Facility that is tapped to a HONI line where the generator is situated at the end of a Generation Facility transmission line.



**Figure 13 - Generation Facility Tapped to HONI HV Line via Facility Owned Transmission Line**

### 3.1 HIGH VOLTAGE INTERRUPTING AND ISOLATING DEVICES

A three phase High Voltage Interrupting device (HVI) along with a motor operated disconnect switch is the point of isolation for the Generation Facility from the HONI system. The HVI may be a circuit breaker (preferred) or other similar device such as a circuit switcher dependent on HONI's authorization. The actual demarcation point between HONI and the Generation Facility is the jaw of the isolating switch/link. This switch/link is owned and maintained by the Generation Facility Owner. Some performance requirements for HVIs are given in the TSC; however, additional requirements may be necessary in some cases as determined by IESO's or HONI's studies (e.g. increased TRV values etc.).

The three-phase disconnect switch/isolating device is required at the Connection Point as a visual indicator confirming isolation of the Generation Facility from the HONI network for safety purposes. The three-phase isolating device must be visible from outside of the Generation Facility fence or property line.

### 3.2 HVI FAILURE PROTECTION

The HVI device at the Generation Facility Switching Station requires breaker failure protection. This protection is necessary should the HVI fail to open while required to do so from either the Generation Facility's protections or from transfer trip signals received from HONI protections. The breaker failure protection simultaneously sends a transfer trip signal to the generator HVI at the remote end of the Generation Facility's transmission line and sends a transfer trip signal to HONI to trip its line terminal stations breakers as shown in Figure 14.

The following is a list of requirements for Generation Facility breaker failure protections:

- The breaker failure protection need not be duplicated and preferably should be supplied from the "A" battery supply.
- The breaker failure protection should recognize mechanical failure or the inability of the HVI to extinguish the arc under fault conditions.
- The breaker failure protection signal must:
  - Seal in for 45 seconds to ensure that no reclosing occurs from HONI breakers.
  - Be supervised by status of the motorized disconnect switch

HONI's line breakers at the terminal stations also have breaker failure protection. Any one of these breakers could fail for a fault outside of the Generation Facility. These breaker failure protections will send a transfer trip signal to the HVI at the Generation Facility's Switching Station should any one of them fail as shown in Figure 15. This tripping signal is sealed in by HONI at the sending end for 45 seconds which may be used by the Generation Facility for transfer tripping discrimination of received signals.

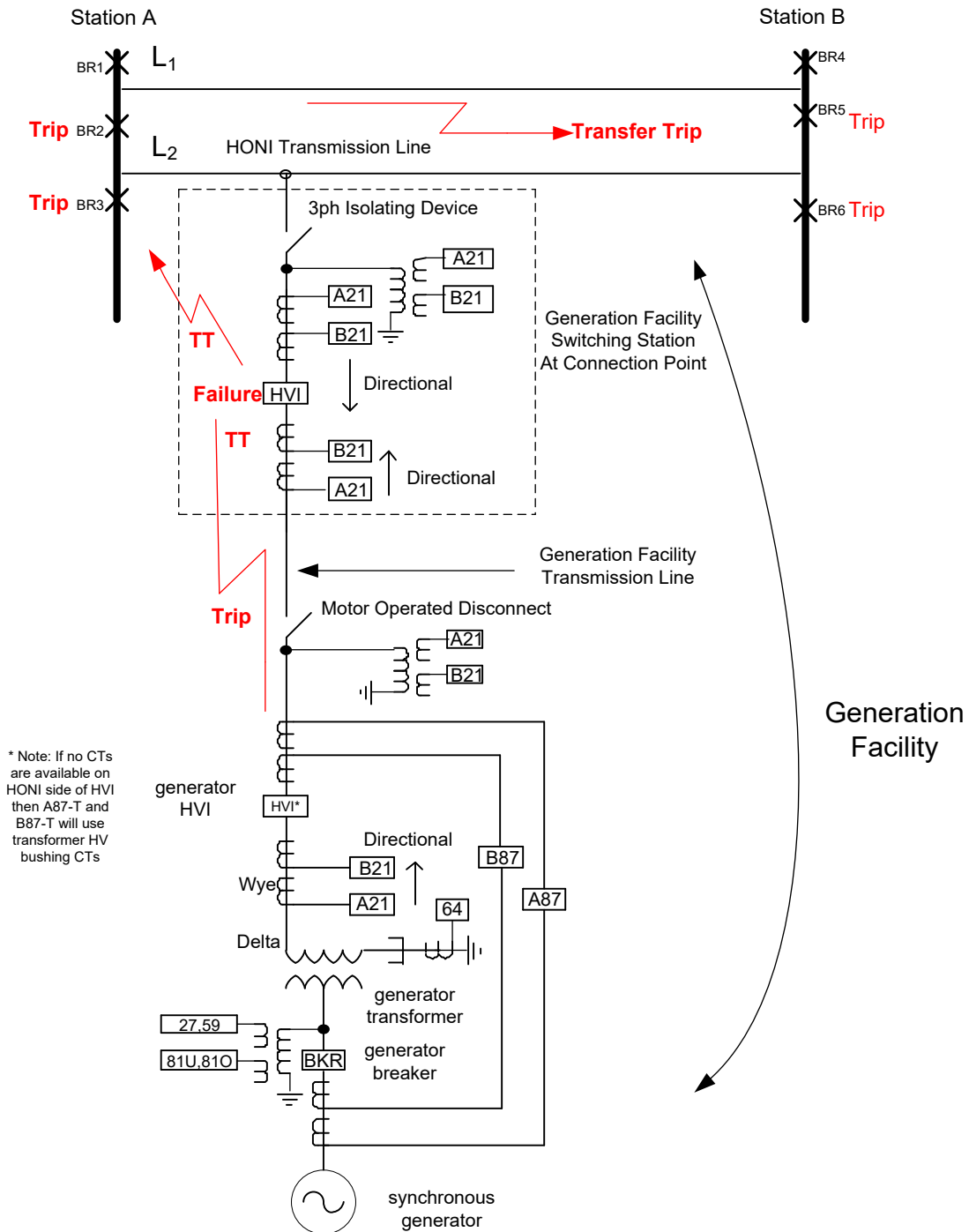
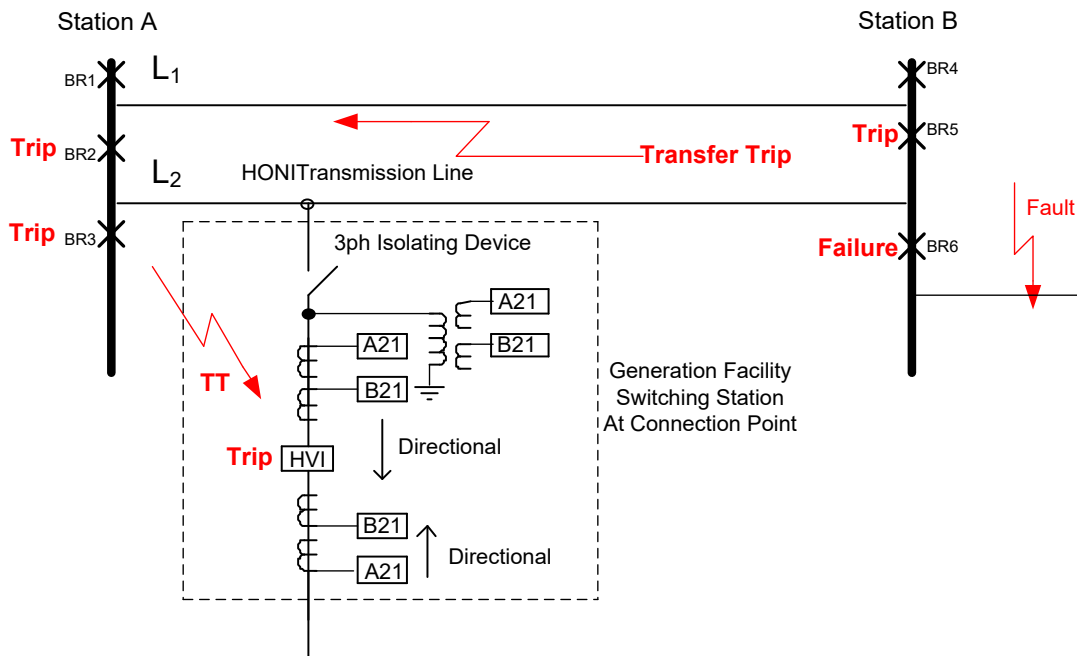


Figure 14 - Generation Facility Switching Station HVI Breaker Failure Protection





**Figure 15 - Breaker Failure Transfer Trip Signal Received from HONI**

The generator HVI must also be provided with breaker failure protection. This breaker failure protection simultaneously transfer trips the HVI at the Generation Facility’s Switching Station and trips the generator breaker as shown in Figure 16. This protection is necessary to prevent HONI from feeding into a fault on the Generation Facility’s transmission line when the generator HVI fails.

The generator breaker must also be provided with breaker failure protection. The generator breaker failure protection simultaneously trips the generator HVI and shuts down the generator by tripping its field breaker (in the case of a synchronous generator) and removing its prime mover as shown in Figure 17. This is necessary to prevent HONI from feeding into a fault in the Generation Facility with the generator breaker having failed.

[Figure 16 Follows]

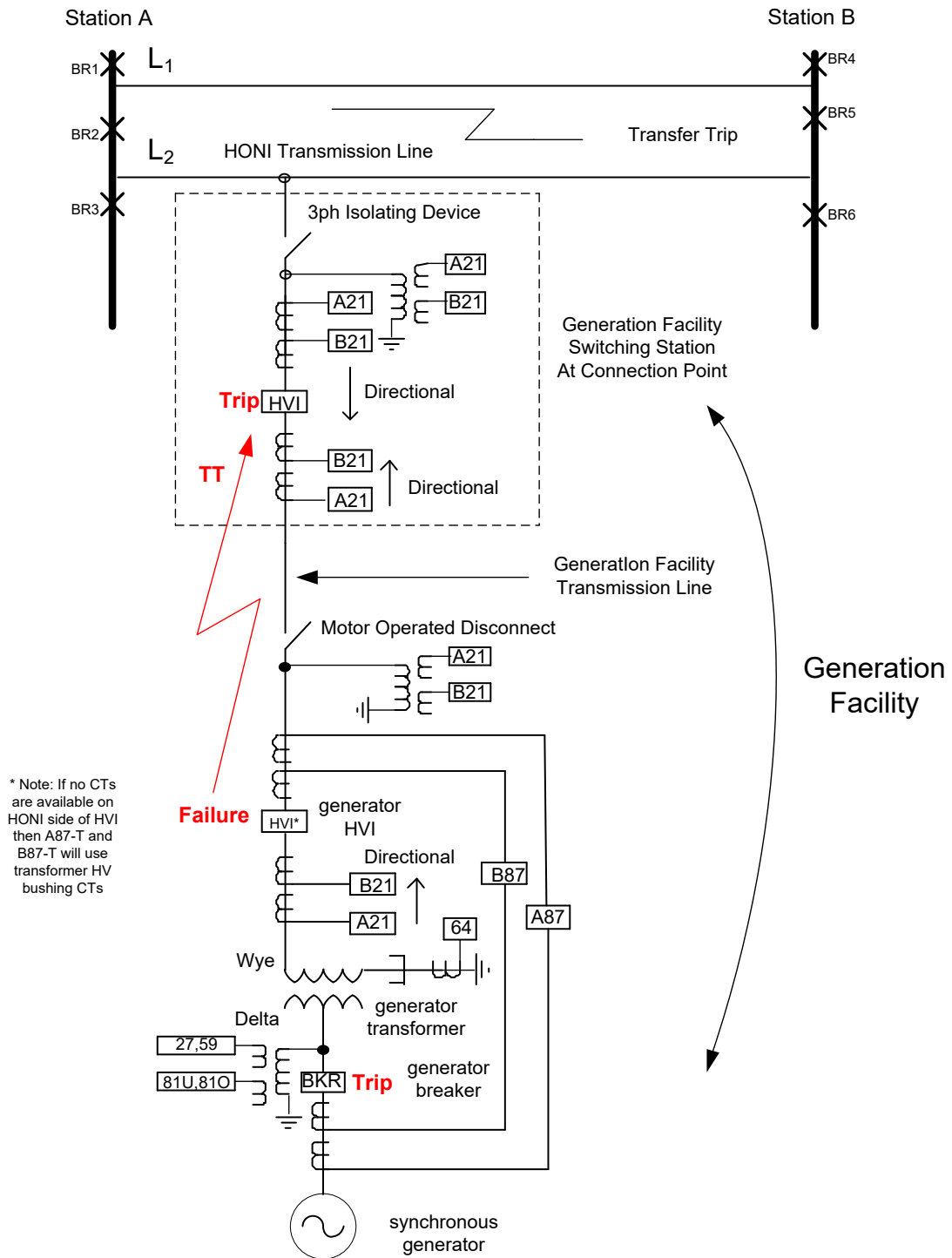
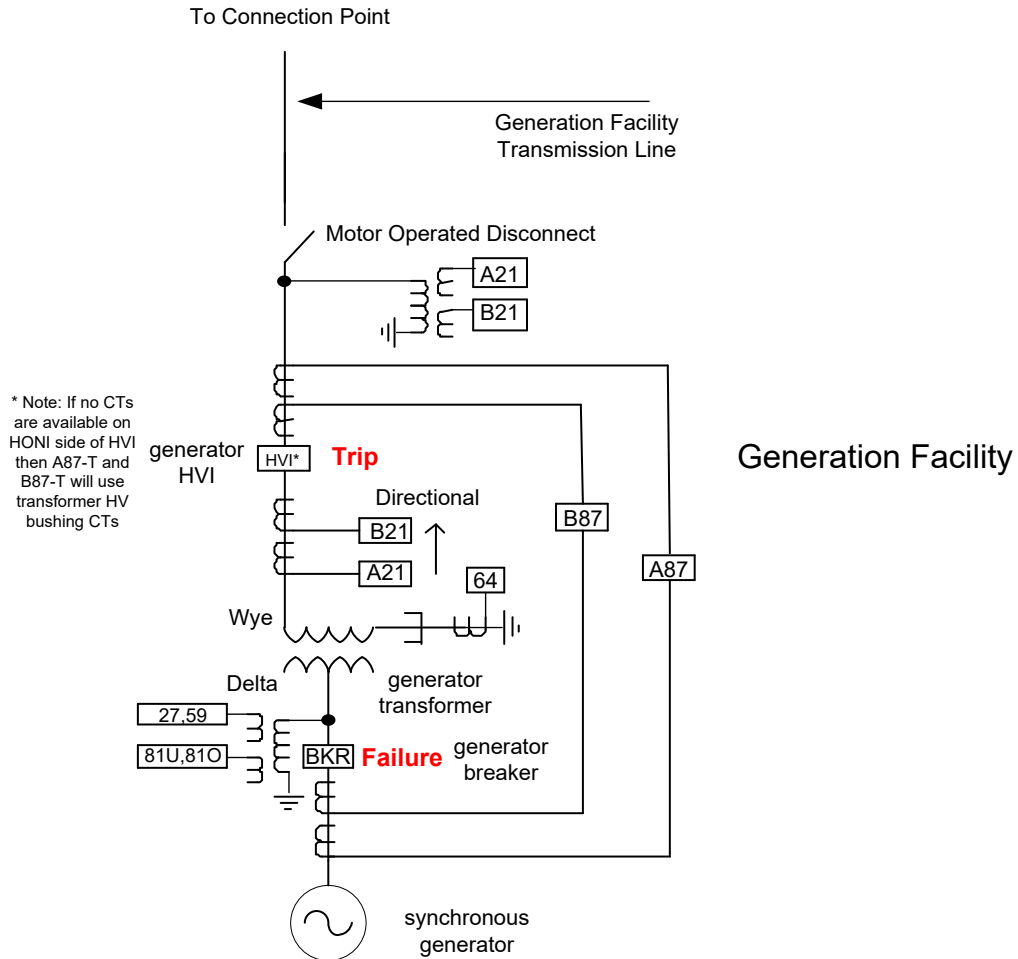


Figure 16 - Generator HVI Breaker Failure Protection



**Figure 17 - Breaker Failure Protection for Generator Breaker**

### 3.3 HVI RECLOSING

Automatic reclosing of the Generation Facility HVI is not permitted as HONI must control reclosing and energization of the line.

HONI utilizes a single shot automatic reclosing attempt for transmission line tripping with no prior initiation to the Generation Facility provided.

### 3.4 TRANSFER TRIP RECEIVED FROM HONI

When HONI's line protections operate they must isolate the entire line zone to eliminate all in-feeds to a line fault. In order to achieve this, HONI also sends a transfer trip signal to the HVI at the Generation Facility. The transfer trip signal when received by the Generation Facility trips the interfacing HVI and initiates its breaker failure protection.

The Generation Facility will receive transfer trip signals sent from HONI's A and B line protections. A and B transfer trip communication channels transmitted over Main and Alternate diversified communication routes are required which in many cases need to be geographically diverse. Leased circuits alone generally do not meet the necessary diversity requirements. Where the Generation Facility is deemed not to be NPCC impactful for uncleared HV faults, a single route for the two transfer trip signals may be sufficient between the Generation Facility and HONI's line protections. However, this is to be determined on individual basis by HONI when the PIA is prepared.

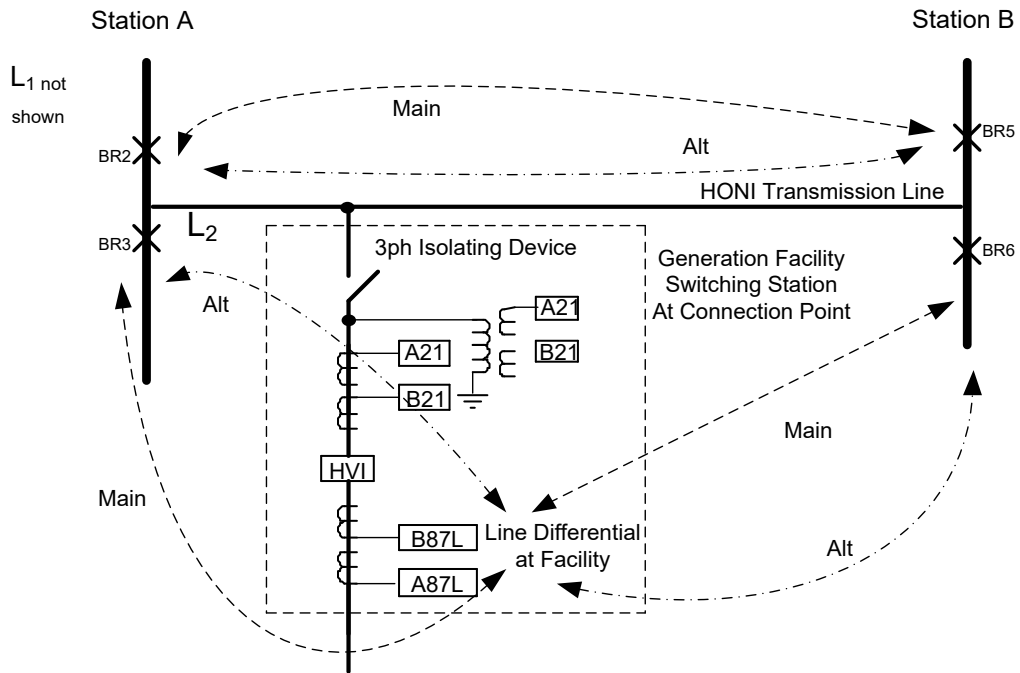
### 3.5 HV LINE PROTECTIONS

HV line protection is required at the Generation Facility's Switching Station to trip its HVI for phase and ground faults on the HONI HV transmission line. The Generation Facility's Switching Station line protection will be definite time delayed to coordinate with HONI line protections in adjacent zones. The Generation Facility's Switching Station line protection must be capable of seeing all phase and ground faults on the HV transmission line following the operation of the HONI line protections having isolated the line from the HONI network. It is unreasonable to expect the Generation Facility's line protection to be set to cover all in-zone remote line faults while the HONI system is simultaneously feeding into the fault. The HONI infeed to the fault is typically higher than the infeed from the Generation Facility thereby creating a comparatively large apparent impedance seen from the Generation Facility looking into the line. However, the requirement for the reach setting on the Generation Facility's line protection will be reviewed on an individual basis.

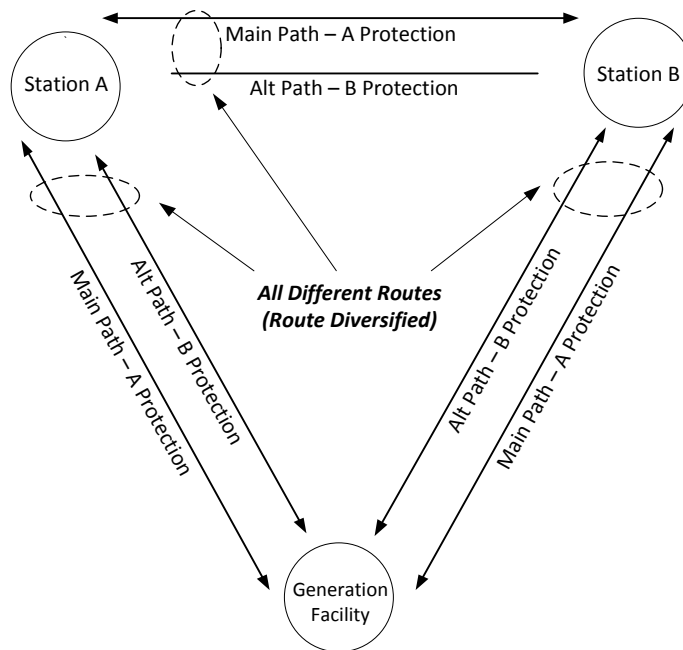
All other provisions for the HONI HV line protections outlined in Section 2.5 for Generation Facilities situated at the line right-of-way are applicable.

HONI may elect to cover the HV line with a multi-ended line differential protection instead of using distance protection. In this case, the Generation Facility's Switching Station protection becomes an integral extension of the HONI protections. Two separate and route-diversified SONET, fiber or digital microwave facilities towards each of the other terminals are required as shown in Figure 18 for a three terminal arrangement. The "A" protection from the Generation Facility to Station A will follow one route (Main) while the "B" protection from the Generation Facility to Station A will follow a second route (Alternate). There will be a total of 6 communication routes – one for each of the three "A" protections and one for each of the three "B" protections - all of which are route diversified from each other. Figure 19 also illustrates the route diversification; however this figure shows only the communications paths in order to highlight the various routes.

An option for a single route of two independent channels towards one of the two terminals may be accepted by HONI on a case-by-case basis subject to the analysis of configuration, media used, type of installation, etc.



**Figure 18 - Route Diversification Required for Line Differential Protection**



**Figure 19 - Route Diversification (Communication Only)**

The Generation Facility Owner is responsible for the protection of the Generation Facility transmission line. Whether the Generation Facility transmission line is deemed NPCC impactful will determine the type of protection necessary. Tele-communications used with the line protections must be Main and Alternate route diversified unless a deviation from this requirement is approved by HONI. Whether or not the Generation Facility infeeding to a HONI line fault is deemed to be NPCC impactful, the time delay must be reviewed by the IESO for system impact.

### 3.6 BLOCKING SIGNALS TO HONI LINE PROTECTIONS

HONI line protections are set to cover the entire HONI line but they also reach into the Generation Facility's transmission line and can unnecessarily trip for faults on this line. When distance protections are used by HONI they must be blocked from operating due to faults on the Generation Facility Transmission Line or beyond into the generator itself. Phase and ground distance protections at the Generation Facility's Switching Station directioned toward the Generation Facility Transmission Line and generator can be used to detect faults also seen by HONI line protections. These protections will send a block signal to HONI to prevent HONI line protections from operating for faults at these locations as shown in Figure 20. The minimum reach requirement for reverse blocking zone will be provided by HONI.

Other provisions for blocking signals to HONI line protections outlined in Section 2.6 for Generation Facilities situated close to the HONI line right-of-way may be considered in some cases as an alternative based on HONI's analysis and approval.

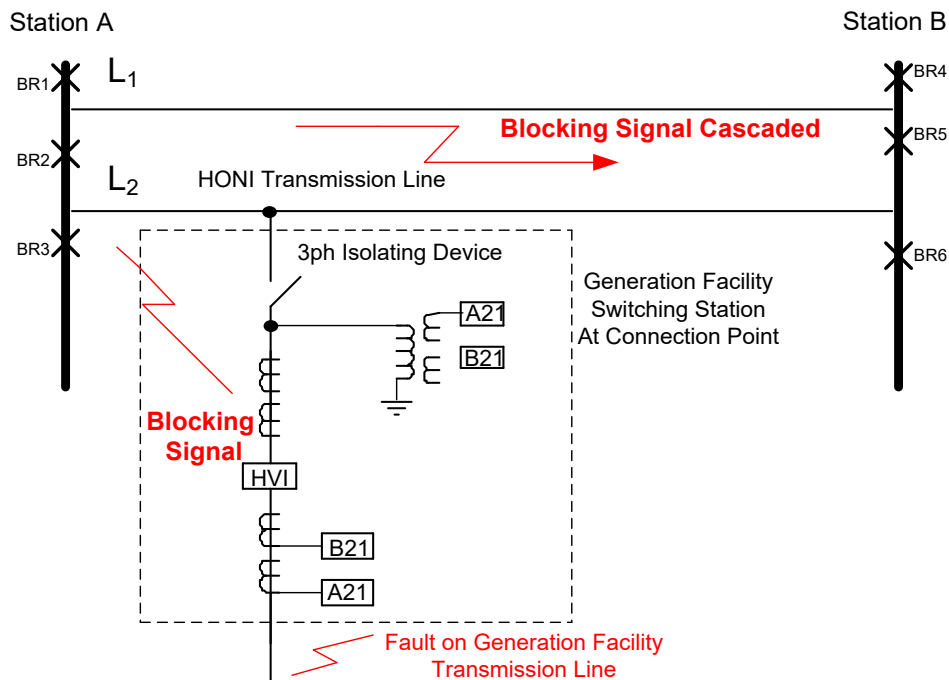


Figure 20 - Blocking Signal to HONI Transmission Line Protections

---

## 4.0 GENERATION FACILITY CONNECTED TO SECTIONALIZED HONI LINE

HONI may elect to sectionalize an HV line and install a switching station for a Generation Facility to connect instead of tapping directly to the line. This is characteristic of, but not limited to, long transmission lines where the HONI line protections may be compromised should the line retain its original length after the connection. In addition, it is to be expected that any connection to a 500 kV line will require sectionalization as determined by HONI. Figure 21 shows the Generation Facility's Switching Station connecting to a HONI switching station where the HONI HV line has been sectionalized. Sectionalization of the HONI line will be determined by HONI upon assessment of the Generation Facility connection requirements.

When connecting to a double circuit, other configurations for the sectionalizing switching station may be required by HONI. Protection for such cases will be defined in the PIA document.

It is expected that the switching station on the HONI transmission line will be owned by HONI. Requirements for a Generation Facility Switching Station will be established at the time of the initial connection assessment.

### 4.1 PROTECTION OF HONI LINE SECTIONS

In the HONI sectionalizing switching station, the HONI HV line protection on each of the two line sections are zoned-off around two of the HONI sectionalizing line breakers.

### 4.2 PROTECTION OF GENERATOR'S LINE

The Generation Facility's line protection is zoned-off around the two HONI breakers connecting HONI to the Generation Facility and trips only these two HONI breakers (see Figure 21).

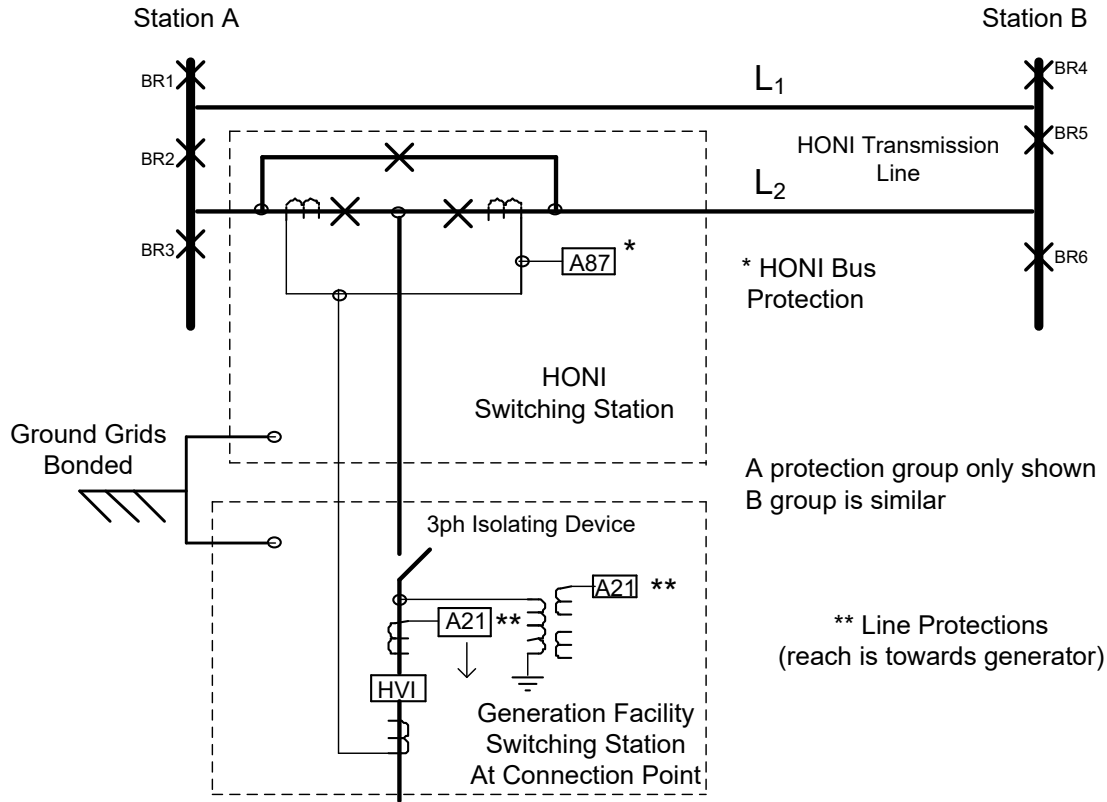
### 4.3 BUS PROTECTION IN THE SECTIONALIZING SWITCHING STATION

HONI's ring bus is inherently covered in segments by each of the line protections.

For a rare case where protection is configured so that copper CT cables need to connect HONI CTs and the Generation Facility's CTs, the two station ground grids must be solidly bonded. This bonding is necessary when the two switching stations are in close proximity as defined by HONI requirements. Should a fiber-based solution be implemented this requirement may not be necessary.

NOTE: The Generator's own ground grid must meet, as standalone, ESA requirements for the ground grid performance before HONI can consider the bonding of the ground grids. It is not acceptable to rely on HONI's ground grid nor the transmission line skywire to meet the required parameters for the Generation Facility's grounding. Exceptions will only be considered for ex-

treme cases (e.g. extreme soil or configuration conditions) where it is not possible to meet standalone requirements. The acceptance of any deviation is at the discretion of HONI upon the review of the Generation Facility Owner's grounding study where (1) satisfaction is achieved due to exhaustion of all possibilities; and (2) the combined grids will not expose HONI's system to unacceptable risks.

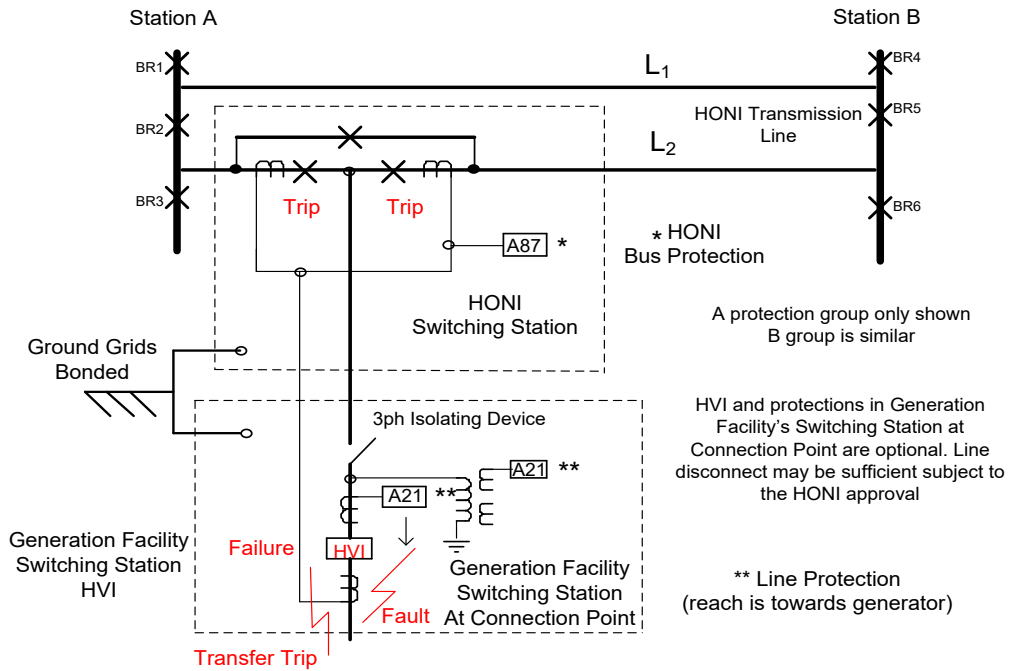


**Figure 21 - Generation Facility Switching Station and HONI Switching Stations for a Sectionalized HV Line**

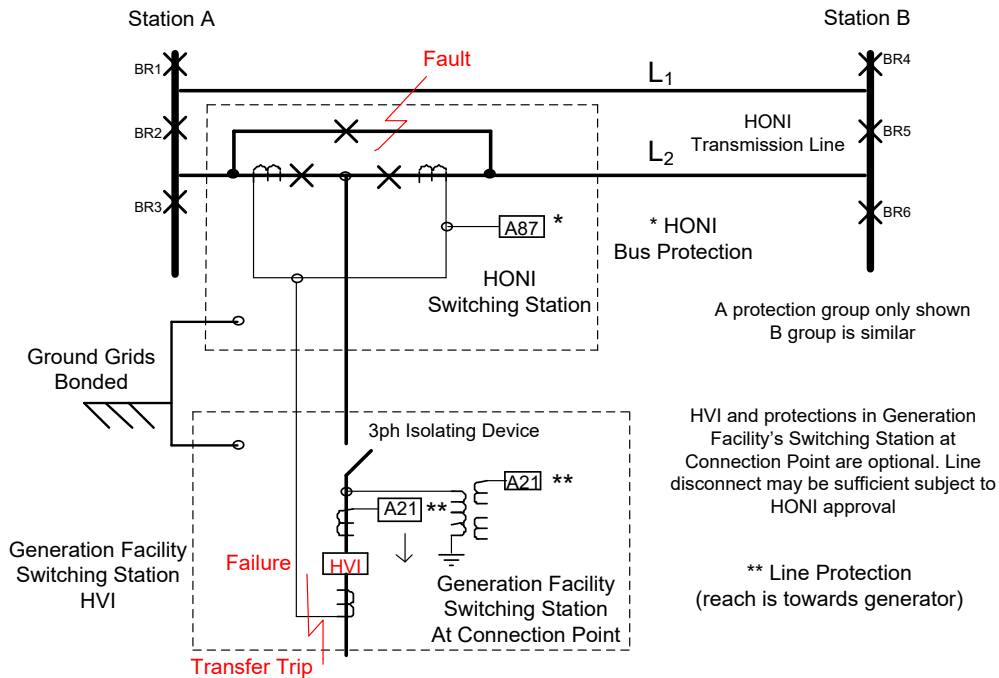
#### 4.4 GENERATION FACILITY HVI BREAKER FAILURE PROTECTION

The Generation Facility Switching Station HVI must be provided with breaker failure protection. The breaker failure protection simultaneously trips the HONI breakers and transfer trips the generator HVI. This protection is necessary for two reasons. The first reason is to prevent HONI from feeding into a fault on the Generation Facility Transmission Line with the Generation Facility Switching Station HVI having failed for a fault as shown in Figure 22. The second reason is to prevent the Generation Facility from feeding into a fault on the HONI bus with the Generation Facility Switching Station HVI having failed as shown in Figure 23.



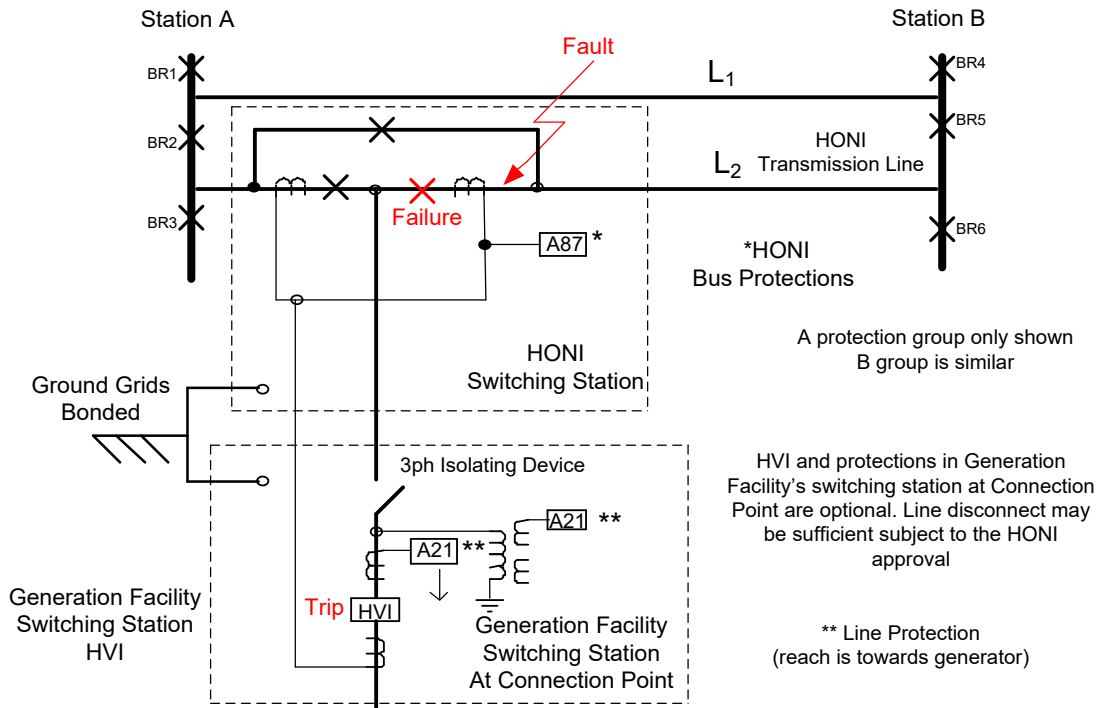


**Figure 22 - Generation Facility HVI Failure Protection with Fault on Facility Line**



**Figure 23 - Generation Facility HVI Failure Protection with Fault on HONI Bus**

The HONI breakers are also provided with breaker failure protection. The breaker failure protection trips the generator HVI (or Generation Facility Switching Station HVI, whichever is at the Connection Point). This protection is necessary to prevent the Generation Facility from feeding into a fault on the HONI bus with the HONI breaker having failed as shown in Figure 24.



**Figure 24 - HONI Breaker Failure Protection for a Fault on the HONI Bus**

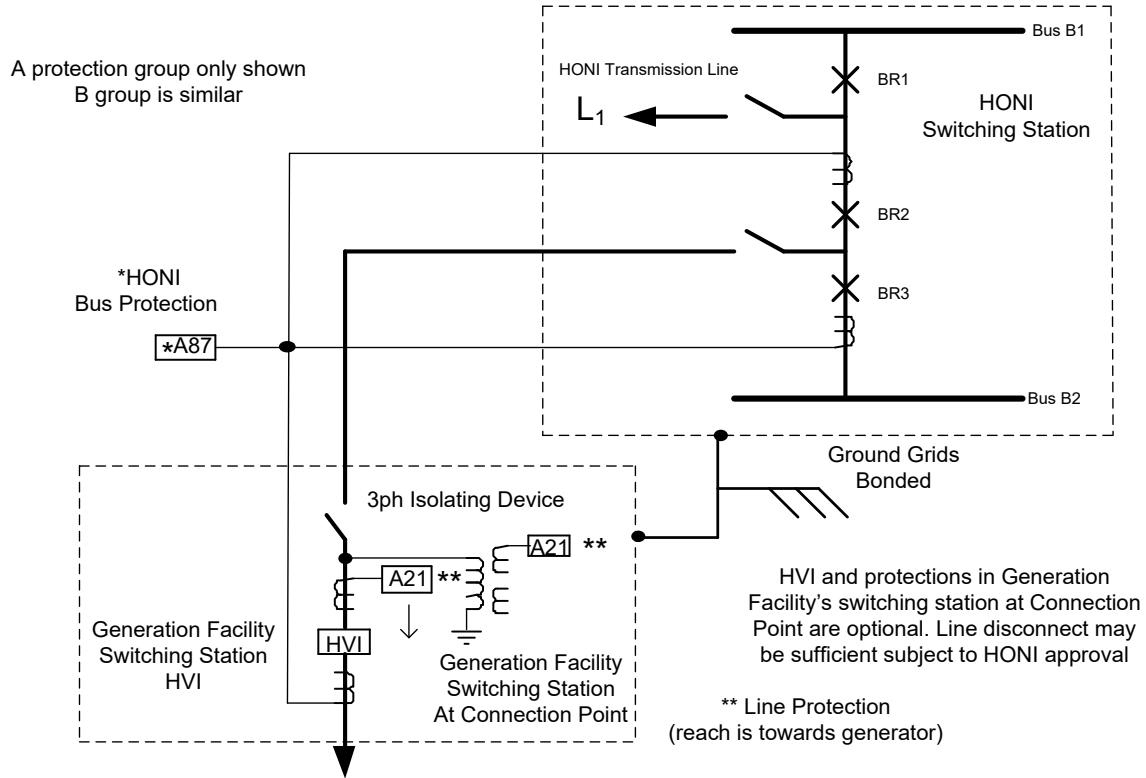
The breaker failure trip signal from the HONI breaker is sealed-in, by convention, at the sending end for 45 seconds.

## 5.0 GENERATION FACILITY CONNECTED TO HONI HV STATION

It may be possible to have a Generation Facility Transmission Line connect to a HONI station by terminating the Generation Facility Transmission Line on a HONI diameter or a ring bus.

The requirements for the protection of the Generation Facility Transmission Line will be similar to the requirements for the protection when the previously described switching station arrangement (Section 4.0) is used. The design for the terminal station shall be done by HONI and per HONI's standards.

Figure 25 below shows one of the possible in-station connection arrangements where a differential protection is used to protect the line from the Generation Facility Switching Station to a diameter in a HONI station.



**Figure 25 - Generation Facility Connected to HONI Station Diameter**

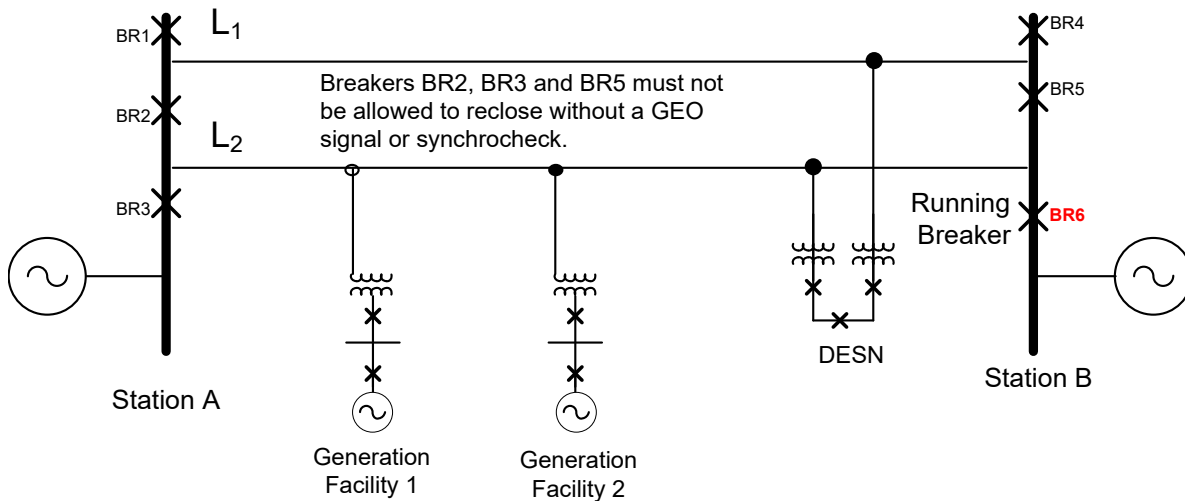
## 6.0 AUTOMATIC RECLOSING

When a Generation Facility is connected to HONI's transmission system, a Generation End Open (GEO) signal from the Generation Facility to the HONI line terminal station where reclosure is enabled may be required. This signal indicates that all phases of generation are isolated from the transmission line and supervised reclosure of the line from HONI breakers would be allowed to proceed. Without the GEO signal received at the HONI terminal station automatic reclosing is blocked. The prevention of automatic breaker reclosing at the HONI terminal station benefits the Generation Facility as the HONI system and Generation Facility voltages are most likely out of synchronism even after a very short time delay. Out-of-phase reclosing may seriously damage the generator.

The preferred solution is for HONI to arrange their reclosure settings as follows: the HONI (operator chosen) preferred energizing breaker would be set at undervoltage plus time (UVT). All other breakers connected to the line would be set to synchrocheck reclosing by HONI operators

where possible. Regardless of the whether UVT reclosing is used by HONI or not, the need for a GEO signal from the Generation Facility will be determined by HONI at the time of the connection assessment.

In the example shown in Figure 26, breaker BR6 is the preferred energizing breaker and it set to undervoltage plus time (UVT). This means that it would not reclose as it senses voltage on the line (in this case due to a Generation Facility not being tripped). Other breakers would most likely not reclose as they are set for synchrocheck. By then, the voltages would be sufficiently out-of-phase thereby preventing reclosing.



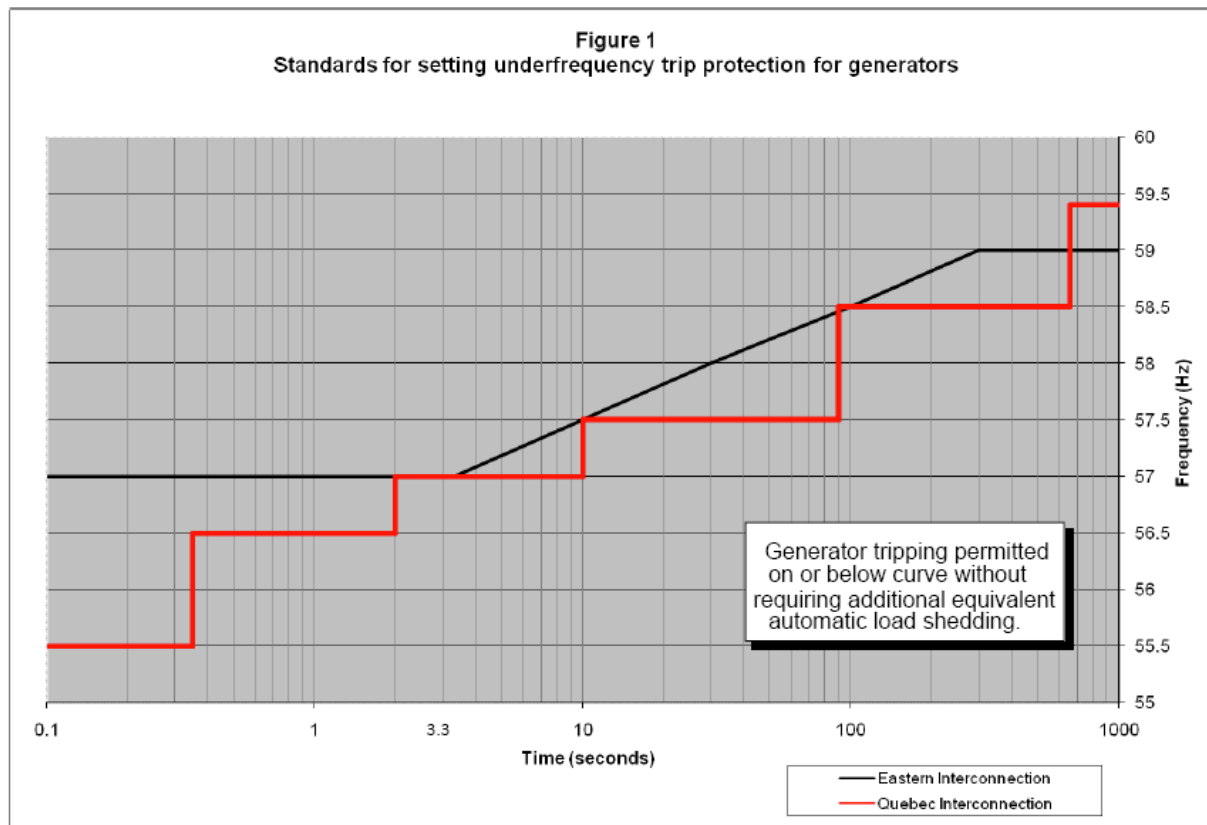
**Figure 26 - Automatic Reclosing of Terminal Breakers**

HONI reserves the right to decide which reclosing implementation is in the best interest of all parties.

## 7.0 UNDER-FREQUENCY PROTECTION

Rotating turbine-generator sets have mechanical resonances at particular non-synchronous shaft speeds. These machines are frequently protected using under-frequency relays. It is important that generator under-frequency protection be coordinated with the HONI underfrequency load shedding programs.

To facilitate such coordination, NPCC Directory #12 [3] requires generators to be able to operate reliably at abnormal voltages and frequencies as shown in Figure 27. NPCC stipulates that generators shall not be tripped for under-frequency conditions in the area above the curve in Figure 27, aside for exceptional cases as provided for in NPCC Directory #12.



**Figure 27 - Generator Under Frequency Protection Requirements [4]**

## 8.0 TELEPROTECTION

Generation Facilities must communicate with HONI for a number of reasons. In most cases, more than one HONI line terminal is involved.

Figure 28 below shows Generation Facility protections must be integrated with terminal Station A and terminal Station B for transfer trip, breaker failure, blocking and possibly Generation End Open (GEO) to block automatic reclose without synchrocheck.

In some cases, it is acceptable for the Generation Facility protections to communicate with just Station A, for example. Then Station A will cascade these signals to-and-from Station B via HONI's own communication network. Thus HONI acts as a black box that only needs to be communicated with at one location. However this is not always the case and multiple factors influence the solution. One example is when a line differential protection is used and communications to more than one station is required.

HONI must be notified well in advance as to which terminal Station(s) the Generation Facility Owner plans to communicate with. HONI reserves the right to ultimately decide which station(s) it needs to receive and send protection communication signals from/to.

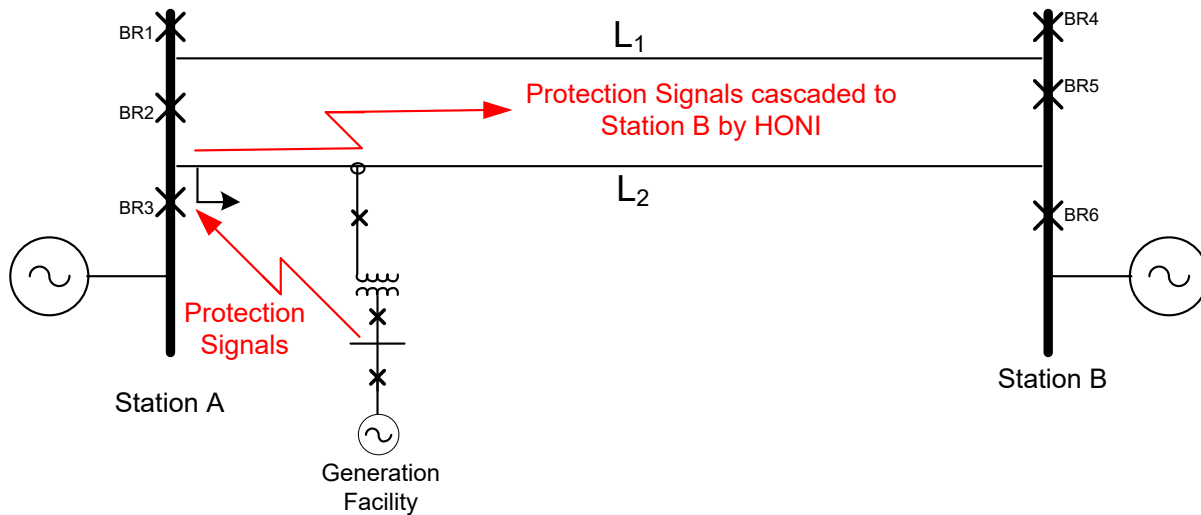
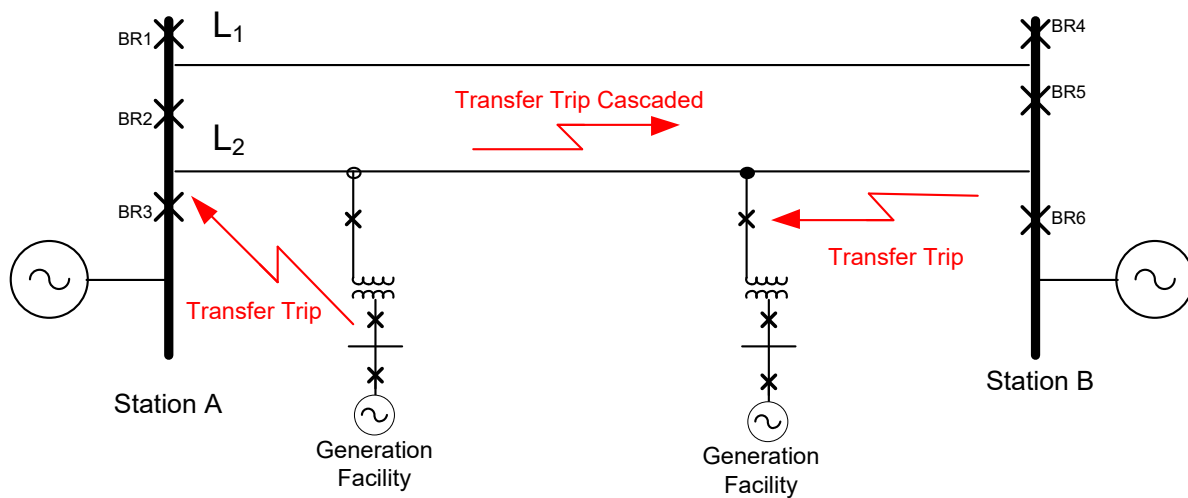


Figure 28 - Cascaded Generator Communications with HONI

## 9.0 COMMUNICATIONS WITH MULTI-TAPPED GENERATION FACILITIES

In some cases more than one Generation Facility is tapped to a HONI transmission line. HONI will transfer trip each of the tapped Generation Facilities for line faults or for a breaker failure on a breaker. Each Generation Facility must send breaker failure, blocking and possibly GEO signals to at least one HONI line terminals as discussed in the preceding section. However, each Generation Facility is not obliged to transfer trip other Generation Facilities tapped to the same line. This applies to line protections as well as breaker failure signals. It is recommended that dialogue be established by each Generation Facility Owner for HONI to consider using the breaker failure trip signal received to transfer trip the other tapped Generation Facilities as shown in Figure 29 below.

[Figure 29 Follows]



**Figure 29 - Generation Facilities Tapped Directly to Transmission Line**

## 10.0 GENERATION FACILITY STATION PROTECTIONS

All proposed protections and protection settings must be submitted by the Generation Facility Owner to HONI and the IESO well in advance of the in-service date to allow for review and changes as required by either authority. It is strongly advised that this date be pre-determined and agreed to by HONI and the IESO at the outset of the project to mitigate in-service delays should the submitted material not meet HONI or the IESO requirements.

The Generation Facility Owner is expected to specify protections applying good utility practice which includes but is not limited to, maintainability, operability and overlapping of protection zones. It is recommended that the latest version of the IEEE Guide for AC Generator Protection Std. C37.102 (prepared by the Power System Relaying Committee of the IEEE Power and Energy Society) be referenced.

### 10.1 COMMUNICATION MEDIA FOR NPCC IMPACTIVE FACILITIES

All Generation Facilities deemed to be NPCC impactive must use 'dark fiber' or microwave for all protection related communications with HONI facilities such as transfer trip, blocking signals and GEO signals. The dark fiber can be connected to T1 multiplexers where multiple DS0 channels can each be used for these various functions. It is not acceptable to use a leased T1 service for these purposes.

---

## 10.2 GENERATION REJECTION OF WIND FARMS FROM A REMEDIAL ACTION SCHEME

The Ontario Resource and Transmission Assessment Criteria [5] stipulates that: “an SPS [RAS] proposed in a connection assessment [CIA] must have full redundancy and separation of the communication channels, and must satisfy the requirements of the NPCC Type I SPS criteria to be considered by the IESO”.

Each of the following arrangements would provide full redundancy in its response to a generation rejection (GR) signal from a RAS. The Generation Facility will then receive conditional approval to connect from the IESO:

- 1 For a connection arrangement without an intermediate voltage level (refer to Figure 30):

### Option 1

- i. Initiate tripping of the LV generator breakers together with the initiation of their breaker failure protections. Should any LV generator breaker fail to operate, tripping of the Generation Facility HVI would then be initiated.
- ii. No further tripping is to occur should the Generation Facility HVI fail to operate.

### Option 1 Alternative

- i. Initiate simultaneous tripping of all LV generator breakers together with the Generation Facility HVI, without initiating any breaker failure protections.

- 2 For a connection arrangement with an intermediate voltage level (refer to Figure 31 and Figure 32):

### Option 2

- i. Initiate tripping of the LV generator breakers together with the initiation of their breaker failure protections. Should any LV generator breaker fail to operate, tripping of the MV breaker would then be initiated.
- ii. No further tripping is to occur should the MV breaker fail to operate.

### Option 2 Alternative

- i. Initiate simultaneous tripping of all LV generator breakers together with the MV breaker, without initiating any breaker failure protections. This Option would avoid interrupting the station service supply.



Option 3

- i. Initiate tripping of the MV breaker of the unit step-up transformer together with the initiation of its breaker failure protection. Should the MV breaker fail to operate, tripping of the Generation Facility HVI would then be initiated.
- ii. No further tripping is to occur should the HVI fail to operate.

Option 3 Alternative

- i. Initiate simultaneous tripping of the Generation Facility MV breaker and HVI, without initiating any breaker failure protections.

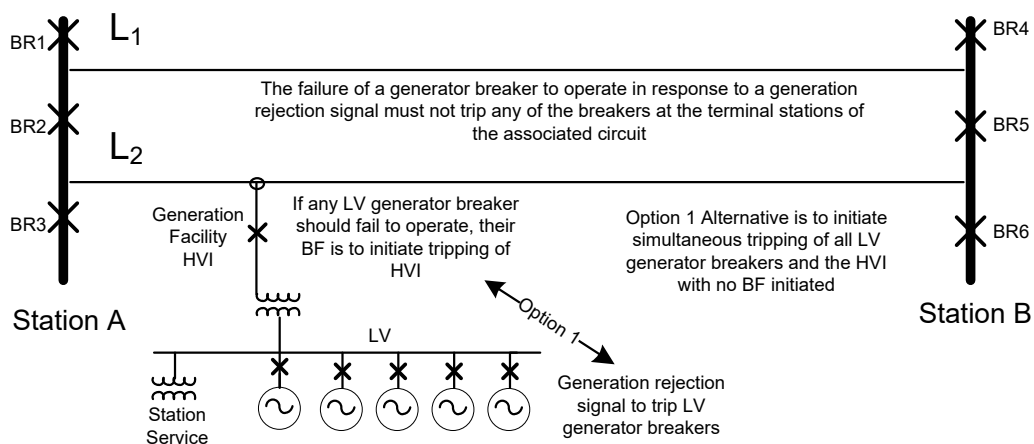
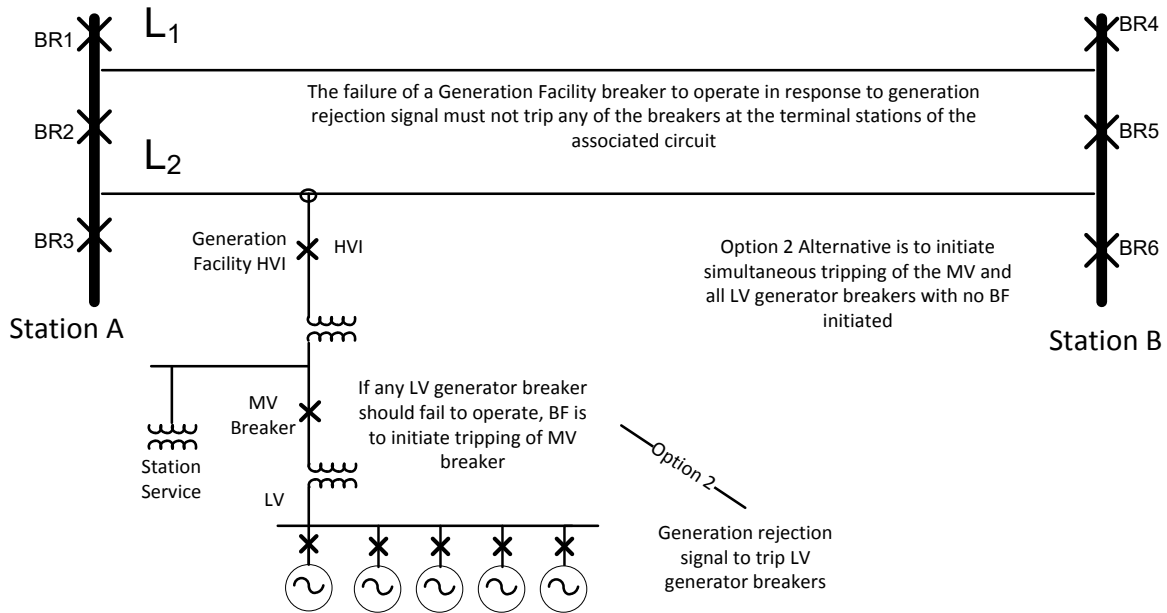
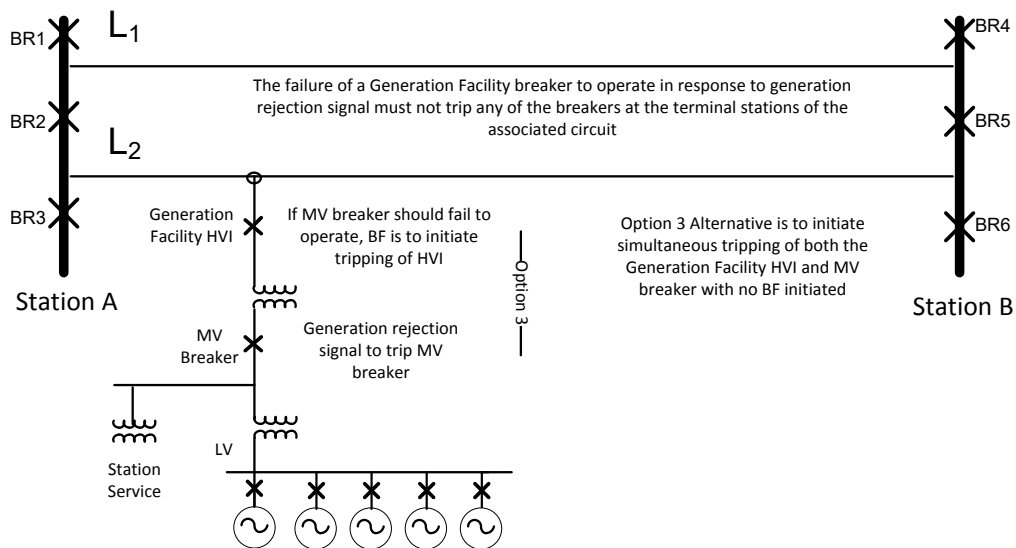


Figure 30 - Generation Facility Connection without Intermediate Voltage Level – Option 1



**Figure 31 - Generation Facility Connection with Intermediate Voltage Level - Option 2**



**Figure 32 - Generation Facility Connection with Intermediate Voltage Level - Option 3**

If none of the above options are possible, HVI breaker failure can be initiated with IESO approval.

---

## 11.0 GENERAL TELECOM REQUIREMENTS

All Generation Facility connections to the HONI transmission system must meet the following requirements:

- The Generation Facility Owner is expected to provide all necessary media and hardware for the teleprotection channels and RAS (SPS) telecom channels.
- All telecom links must meet the reliability criteria required by the Transmission System Code.
- Where applicable, the requirements of NPCC and/or NERC must also be met.
- Additionally, HONI may extend the requirements based on the characteristic of a design standard or hardware being implemented.
- The Generation Facility Owner can choose their preferred type of media for the telecom channels. HONI will accept the preferred type of media chosen should the selection be feasible and compliant with the reliability requirements and applicable standards.
- The use of HONI's existing telecom capacity by the Generation Facility Owner for use in Generation Facility protection is not to be expected.
- The Generation Facility Owner needs to be aware that the telecom channels provided for the teleprotection of transmission line may not be applicable for the RAS application. The hubs for RAS may be located in different terminal stations and therefore additional telecom routes may be necessary for implementation of generation rejection requirements. Once the requirements for RAS and line protection are established, HONI will specify the termination of the telecom channels. The path diversity requirements can also be specified based on the IESO's classification of the Generation Facility.
- Additional telecommunications need to be established with IESO and HONI's Grid Control Centre(s) for operation monitoring purposes. This subject is not covered in this document.

## 12.0 DISTURBANCE MONITORING

Disturbance monitoring and GPS clock requirements are not covered by this document. The Generation Facility Owner can review applicable NERC's PRC standards and consult with IESO.

---

## 13.0 DC STATION SERVICES

DC Station Services are not covered by this document. The applicable requirements of the Transmission System Code and applicable NERC or NPCC must be met.

Due to its impact on protection reliability and possible compliance requirements, HONI will review the DC system design to a level appropriate for the Generation Facility's classification and potential impact on HONI's assets.

## 14.0 REFERENCES

- 
- [1] NPCC Regional Reliability Reference Directory #4 Bulk Power System Protection System Protection Criteria, December, 1, 2009
  - [2] NPCC Regional Reliability Reference Document Directory #7 Special Protection Systems, July 9th, 2013
  - [3] NPCC Regional reliability Reference Directory #12 Under frequency Load Shedding Program Requirements, July 9<sup>th</sup>, 2013
  - [4] NPCC Standard PRC-006-NPCC-1 Automatic Underfrequency Load Shedding
  - [5] IESO Ontario Resource and Transmission Assessment Criteria, Issue 5.0, IMO\_REQ\_0041